

A supplement for use with

2002



STAR TREK
THE ROLE PLAYING GAME

THE KLINGONS

A SOURCEBOOK AND CHARACTER GENERATION SUPPLEMENT



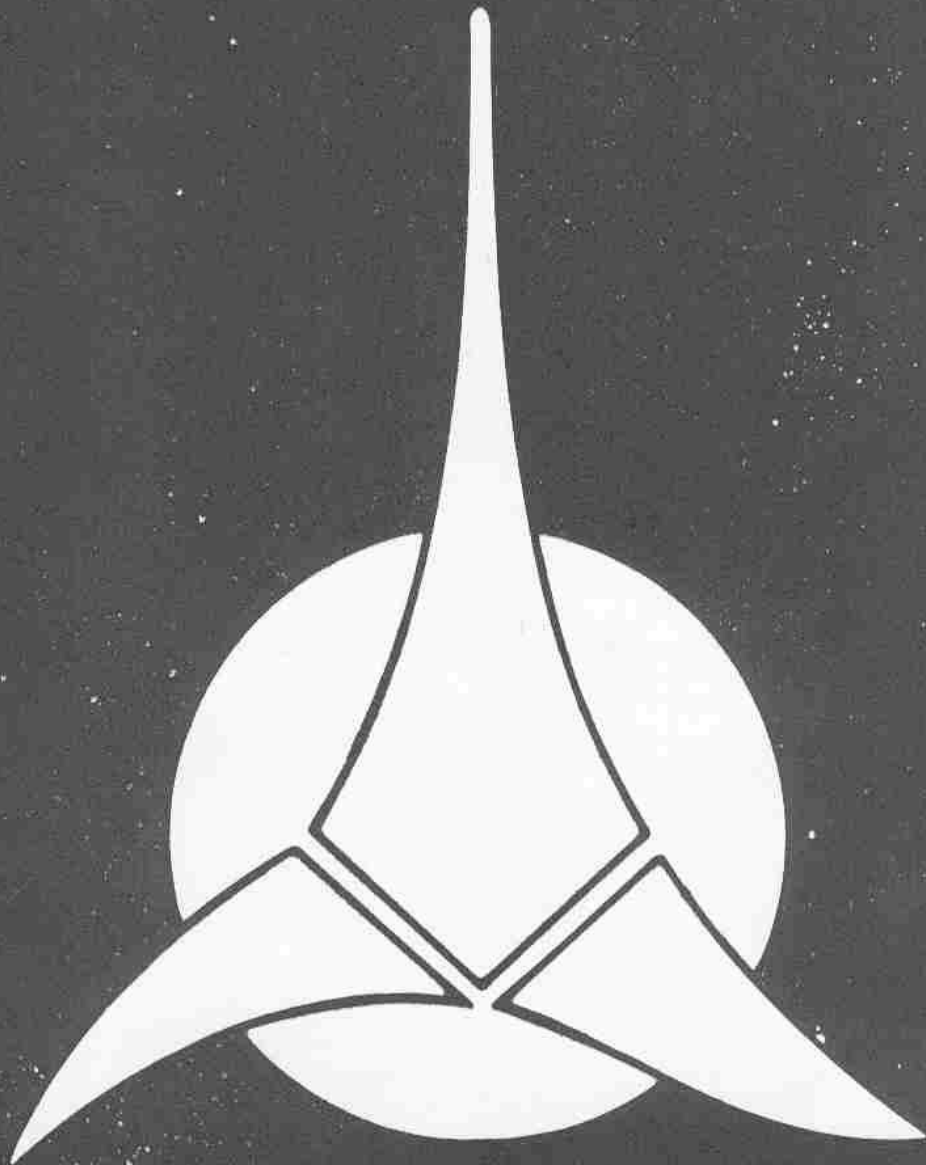

KLINGON

Copyright © 1966, 1983 Paramount Pictures Corporation
All Rights Reserved
Printed in the United States of America

STAR TREK is a trademark of Paramount Pictures Corporation

No part of this book or the contents of this supplement may be reproduced in any form, or by any means without permission in writing from the publisher.

STAR TREK™: The Role-Playing Game is manufactured by FASA Corporation under exclusive license from Paramount Pictures Corporation, the trademark owner.

Published by FASA Corporation
P.O. Box 6930
Chicago IL 60680

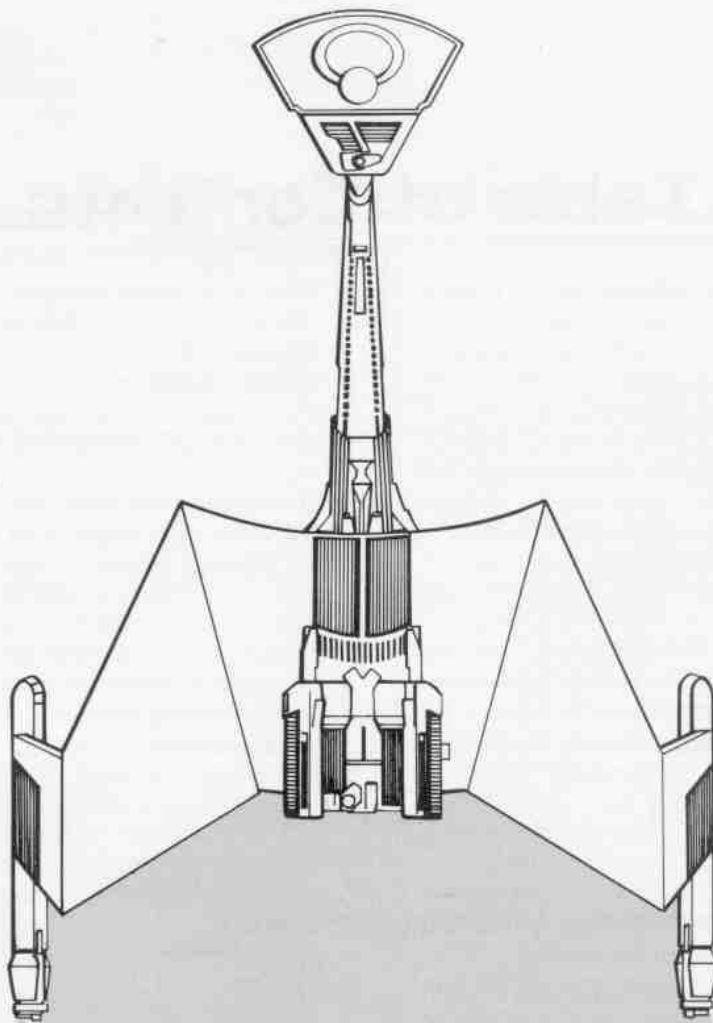

DEDICATION:

To Michael Ansara, William Campbell, and John Colicos — whose portrayals of Klingons rose above the level of "villains" and made them come alive as individuals. Of such men are Empires made . . .

THE KLINGON EMPIRE:

A sourcebook, background expansion, and character system for STAR TREK: The Role-Playing Game.

Game design by Fantasimulations Associates

Designers: John M. Ford
Guy W. McLimore, Jr.
Greg K. Poehlein
David F. Tepool

Cover Art : Mitch O'Connell

Interior Illustration : Mitch O'Connell and Dana Knutson

Graphic Design : Dana Knutson

Table of Contents

Introduction	5
Using This Book	7
Klingon Character Generation	8
Character Attributes	8
Character Sheet	11
Pre-Academy	12
Imperial Klingon Star Academy	13
Cadet Cruise	16
Command School	17
Post Academy Experience	18
Skills and Skill Descriptions	20
Physiology and Medical Aid	23
Klingon Physiology	23
Klingon Medical Equipment	23
Equipment and Weapons	27
Planetside Adventures	36
History, Structure and Organization - The Klingon Empire	39
Klinzhai - The Klingon Homeworld	39
Early History of the Klingon Race	40
Klingon Culture and "Religion"	40
Extents of the Klingon Empire	41
Sociopolitical Structure	42
Imperial Growth Structure	43
Imperial Naval and Marine Ranks	45
Uniforms	46
Insignia	47
Decorations	47
Organization of the Imperial Klingon Forces	50
Shipboards Systems	52
Starship Combat	56
Ship Classifications	56
Battle Language	56
Hull Numbers and Vessel Names	57
Role-Playing and Klingon Imperial Policy	57
Gamemaster Hints and Suggestions	59
A Short Note: Klingon Epithets	63
Designer's Notes	64

Introduction

It is impossible to imagine what STAR TREK would have been like without the Klingons. Some of fiction's most interesting characters have been villains. Somehow, we appreciate a fictional hero more when his/her virtues are compared with the vices of a villain. Tom Sawyer needed Injun Joe, Holmes required the presence of Moriarty, and Captain Kirk would not be the same without Kang, Koloth, Kor, and their kin.

STAR TREK went beyond using the Klingons as cardboard foes. Certainly, they began that way, but something in the way they were presented sparked the imagination of the fans. More than any other alien race (except the Vulcans), the Klingons intrigued the fans. Who were the Klingons, and why did their culture develop in directions so in opposition to the familiar Federation?

In some individual Klingons, the series showed us some excellent, detailed characterizations. Captain Koloth, played brilliantly by actor William Campbell, was almost charming in a sneaky sort of way. Jovial and sarcastic, he obviously enjoyed his battle of wits with Kirk in *The Trouble With Tribbles*. Commander Kor, on the other hand, led his Organian occupation force in *Errand of Mercy* with ruthlessness and deadly precision.

In Kang (portrayed by the unforgettable Michael Ansara — no stranger to the villain's role), commander of a disabled Klingon ship whose crew is brought aboard the *Enterprise*, we found that even a hard-boiled Klingon officer can learn to make peace — when it is necessary to do so (as it was to remove the entity feeding on emotions in *Day of the Dove*).

In the process of presenting interesting stories featuring Klingons, the series gave us only a few tantalizing looks at the culture and history behind the fascinating individual characters. In *The Savage Curtain* we meet Kahless the Unforgettable, the ancient Klingon who created his race's traditions of treachery and tyranny, but we learn virtually nothing else of Klingon history. Klingon technology is revealed in bits and pieces in the series, but Klingon social customs remain a mystery.

To further confuse matters, STAR TREK: The Motion Picture introduces us to an entirely different breed of Klingon — less human in appearance and demeanor with even greater savagery in battle. It is a brief glimpse to be sure, before three D-7M battlecruisers are obliterated by V'Ger, but it opens a whole new chapter in the Klingon saga.

Even so, why the drive to answer these questions? Obviously, because fan interest demands it. Why else would the relationship between Kang and his science officer/wife Mara be the object of so much speculation in fan fiction? Why else would science fiction writer Robert Asprin, in his early days as a Trek fan, organize his STAR TREK convention security force as the Klingon Diplomatic Corps? Why else, from the very first, has a Klingon character supplement to STAR TREK: The Role Playing Game been the most widely called for among purchasers of the original game?

But creating a supplement allowing players and game-masters to get into the "persona" of their favorite villains is MUCH harder than doing the same for the Federation characters. The Federation's history and culture is human-dominated — a logical extension of our own. We learn MUCH more about the Federation than we do about the Klingon Empire from the series and from professional and fan fiction written after the series left the air. A supplement on the Klingons meant gleaning what little we WERE told in episodes and elsewhere, and using that as the basis for logical speculation on Klingon history, culture, technology, physiology, psychology, and religion.

Dave, Greg and I were not the only ones facing this problem. Even as STAR TREK: The Role Playing Game was being prepared, author John M. Ford was negotiating with Pocket Books to produce a STAR TREK novel where the central characters were Klingons, with action taking place largely against the background of the Klingon Empire.

John M. Ford (known as "Mike" to his close friends) and I were roommates during my graduate school days and for a time thereafter. Mike introduced me to role-playing games and taught me my first lesson about being a good gamemaster. He was also one of the "shakers and movers" of the Indiana University Science Fiction Club at the time, and we often travelled to SF conventions together. Neither of us was totally aware that our lifetime careers were being shaped in these years. Mike soon became a regular contributor (eventually an editor as well) at *Isaac Asimov's Science Fiction Magazine* and later at *Amazing* and Pocket Books. My own first published work in role-playing (a very early *Dragon* article) was completed while we were roommates, and I have remained in the field ever since.

It was perhaps inevitable that our professional paths should cross again, as Mike's interest in role-playing has kept him active there (when his schedule of science fiction writing permits). Mike remains one of the most prolific contributors to *The Journal of the Traveller's Aid Society*, and is currently chairman of the Games/Computers Committee of the Science Fiction Writers of America.

When we discovered we were working on parallel projects, we couldn't resist a collaboration of sorts. Thus, the research on the Klingon Empire for his upcoming novel *The Final Reflection* (from Pocket Books) became the basis for the background material for this expansion set. *The Final Reflection* promises to be the definitive fictional work on the Klingons (as well as a rousing good adventure story), and I feel sure it will shape the way the Klingons are presented in the STAR TREK universe from now on. (Mike has since been contracted for a second STAR TREK novel, in which the Klingon Empire will play an important part.)

The research-sharing went both ways on the project, with background data on the STAR TREK universe in *The Final Reflection* sometimes being based on data presented in STAR TREK: The Role Playing Game. In this way, the STAR TREK universe inhabited by game players and the

novel's characters remain consistent, and support each other in richness of detail. Thus, what you hold in your hands is not just a game supplement, but is also a background on the Klingon Empire. With its detail and background supported both by the game framework and a major piece of professional STAR TREK fiction, it can lay more claim to being an "official" look at the universe.

A collaboration between fiction author and game designers in this manner is the exception rather than the rule, but we are most happy to have been able to coordinate our efforts in this way. Frankly, we hope it will start a trend. Many thanks to Mimi Panitch and the folks at Pocket Books for their encouragement and cooperation. After all these years, working together again has been a lot of fun for Mike and I, and we hope you will enjoy incorporating the true Klingon Empire into your gaming as much as we have putting this package together. In writing this, I've become convinced that the Klingons are too fascinating to waste just as foes. Try playing from the Klingon perspective and see why they are among the most popular characters in the STAR TREK universe.

Guy W. McLimore, Jr.
Fantasimulations Associates

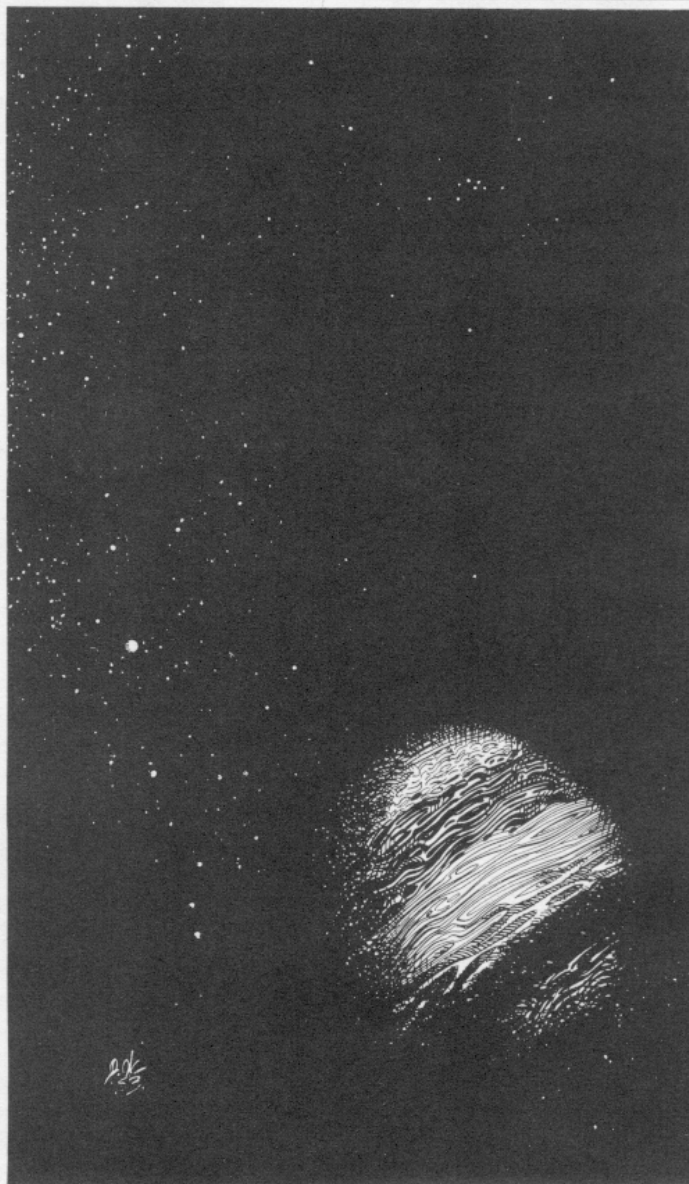

Using This Book

The structure of this expansion book is similar to the basic ruleset. Much of the information in the basic rulebook applies equally to games featuring Klingon characters and Federation characters. For this reason, sections such as the glossary, character basic attributes, skills, combat, planetary creation, etc. are not duplicated in this book. Instead, additional entries in these categories are provided where necessary.

The character creation system in this book provides a method for creating Klingons as player characters. The rest of the book provides detailed background material for structuring a Klingon-centered campaign universe. Much of this material can also be used in Federation-based campaigns where Klingons are prominent non-player foes.

Unlike the Federation material presented in the initial ruleset, most of the Klingon background — weapons, culture, history, and more — is rational speculation rather than research from the series. Care has been taken to avoid speculative detail that contradicts the TV episodes or movies, but most of the “holes” in Klingon background had to be filled from the authors’ imaginations.

To maintain some sort of “authenticity”, co-author John M. Ford provided most of the background detail on Klingon customs and physical structure. His upcoming novel, *The Final Reflection*, is the first professional STAR TREK fiction to present the Klingon point of view so strongly. As such, the speculations he has worked out will likely become part of the greater STAR TREK legend. In turn, some of the background detail of STAR TREK: The Role-Playing Game is adopted in the novel. Of course, the gamemaster and players should feel free to dispense with any part of this speculation in favor of their own views of Klingon life. Until or unless the material presented herein is contradicted by future cinematic speculation, however, this is the view of the Klingon Empire we will see in the future adventures and expansions.

(By the way, *The Final Reflection* is full of little tidbits about the Empire not found here — it wouldn’t be fair to give away all the surprises, after all! As such, it is recommended reading for all Klingon-campaign gamemasters.)

Some of the Klingon background material is presented as excerpts from *An Informal Guide to the Klingon Empire*, by J. Ford and E. Tagore. (For more discussion of this approach, see the Designer’s Notes section at the end of this volume.) This work is a popularly-published book based on the findings of the Committee on the Klingon Estimate, a UFP study group. Excerpts from the book are printed in a distinctive typeface and credited.

(“J Ford”, huh? Hmmm . . . A remote descendent, perhaps? Or is someone fooling around with the Guardian of Forever? I wonder if “our” John M. Ford wears glasses because he’s allergic to Retinax Five . . .)

Where it contradicts the basic ruleset, readers may assume that this book is correct IN RESPECT TO KLINGONS and the Klingon Empire. Where something in this book specifically replaces information in the basic ruleset ON ALL OCCASIONS, the reference will be noted as being

generally applicable. Some changes may be recommended for use with Klingon player characters, but optional if using for Klingon non-player characters in a Federation-based campaign. (For example, certain changes in how Klingons react to phaser stun effects . . .)

You may use this book for Klingon character creation, game reference on Klingon foes, or background reference on Klingon society. The authors find Klingon society a fascinating alien culture. (We do NOT, by ANY means, admire Klingon ideals and practices! ‘Finding a culture fascinating,’ as Mr. Spock would say, “does not imply approval.” To understand all is not necessarily to forgive all. We don’t suggest that you BE a Klingon, only that you try PLAYING a Klingon! After all, when playing “cops and robbers” as children, SOMEBODY had to be the robber! Playing an essentially “evil” role in films or TV shows is harmless, and so is playing an analogous role in games.)



Klingon Character Generation

As the character creation system in the basic rulebook for STAR TREK: THE ROLE PLAYING GAME prepared characters who were Federation Star Fleet officers, the system in this expansion provides player characters who are officers in the Klingon Imperial Fleet. It is even more important that player characters be officers when dealing with the Klingon Empire, as "enlisted personnel" have virtually no decision-making power at all.

Just as with Federation-based campaigns, Klingon Empire campaigns begin with gamemaster and players deciding on the type of vessel to be used as the campaign's home base, and what positions the players will fill on board that ship. Guidelines for choosing Federation characters also apply here, as to types of jobs available, and assuring that players are placed in a decision-making position. Tables of organization and crew lists presented later in these rules should be consulted to find the available positions for the ship selected.

Once a position is decided on for each player, the player can aim for filling that job when going through the character creation process. This may take longer (in terms of service time) for some characters than others, providing for varying ages of characters at the campaign's beginning. Please note that the volatile nature of Klingon politics and promotions make Klingon characters tend to rise through the ranks faster than Federation characters. The average Klingon character will, therefore, be younger than his closest Federation counterpart. This is acceptable, since Klingons have a shorter lifespan than humans and will be subject to aging effects earlier. The life of a Klingon officer is often short and glorious.

IMPERIAL RACE AND FUSION RACE FKINGONS

The Klingons so familiar from the STAR TREK TV series are not truly the original Klingon race. They are rather a genetically-engineered sub-species — a fusion of the physical/genetic traits of both races. Klingon genetics techniques are far advanced of those practiced in the Federation, largely because the Klingons have no restrictions on the use of live, intelligent experimental subjects.

The Klingon/Human fusion sub-race was originally developed to produce Klingons who could more efficiently interact with Human beings — the most numerous racial group in the Federation. Klingon/Human fusions are more comfortable on Human planets and in Human-constructed installations. In addition, they are more successful in negotiating and interacting with humans and human-like races (and also in practicing practical human battle psychology...).

The fusion experiment was so successful that it was repeated with the Romulans, and the Empire

credits this action with helping to achieve the Klingon/Romulan treaties that occurred near the end of the TV series run of STAR TREK. Of course, the Klingons would much sooner conquer both races, but coming to an understanding with the Romulans proved to be a desirable short-term goal which the Empire felt would give them a better position when dealing with the even-more-incomprehensible Humans of the Federation.

Klingon/Vulcan fusions may exist — the Vulcans had contact with the Klingons long before the establishment of the Federation. There are no records of such in Federation databanks. If they exist, they are not numerous. This is partially because the technology was not developed until Humans became the dominant Federation racial group, and partially because of the Klingon distaste for mingling their bloodline with a pacifistic, vegetarian race. No other Federation races are known to have been used to create fusions, either because the race is too unlike the Klingons metabolically (like the Andorians or Edoans), or because the race does not wield the political or military power to make the effort worthwhile (like the Tellarites or Caitians).

The true Imperial Race — the original Klingon form — is seen in the opening sequence of STAR TREK: THE MOTION PICTURE. For the most part, the Imperial Race dominates Klingon politics, though fusions have made greater strides in later years toward political/social acceptance. There is some hint of bigotry among Imperials toward fusions, but the gap between the sub-branches is insignificant in Klingon eyes compared to the gap between Klingons and non-Klingons. A fusion is a different form of Klingon, but a Klingon nonetheless. A non-Klingon is someone to be conquered, used or pushed aside.

CHARACTER ATTRIBUTES

One of the best-kept secrets of the Empire is that the average Klingon is physically a little inferior to the average human. This is contrary to popular human belief, and if one asked persons who had been in a brawl with Imperials it would be found to be contrary to human experience, too. Nevertheless, when hard medical data are compared, the Imperial Race Klingon is in most respects less well endowed than Homo Sapiens Terrestris.

Why hasn't anyone noticed this? (And why do the game charts give bonuses in STR and END? — designer's note). The answer is that ABSOLUTE physical ability is not the same as EFFECTIVE ability.

The Imperial has been in sort of psychophysical battle conditioning since birth — participating in training at school, the Year Games, urged constantly to excel and triumph. So while Klingons actually have LESS muscle power, they do more with what they have.

A corollary to this not to be overlooked is that Federation cultures — even militaristic ones such as Andor

— do not stress fighting to kill, but rather to disable or capture. In shore-leave brawls, which (thank your local gods) have made up the bulk of our violent encounters with the Empire since the Organian detente, our energetic lads aren't usually trying to hurt anybody. This point is frequently lost on the Klingons.

An Informal Guide to the Klingon Empire

The ability categories for Klingon player characters are the same as for any Federation character, and are generated the same way. A different set of die modifiers is involved for Imperial Race and mixed-heritage Klingons, however.

Consult the notes about the Imperial Race and their genetically-engineered human-like cousins before deciding which your character will be. (Klingon/Romulan fusions would be found serving near the Romulan Confederation, as Klingon/Human fusions are found near the Federation.) There are advantages and disadvantages to each. A human/Klingon hybrid will have certain advantages in dealing with humans, but a member of the Imperial Race has more command ability, on the average, over his own kind. Human/Klingon hybrids are luckier and more charismatic, and they live longer than Imperial Race Klingons, but Imperials have more dexterity.

Normally, one will find 80% or more of a ship's crew will be of one type of Klingon. Romulan fusions and Human fusions almost NEVER serve together. Toward the time period covered by *STAR TREK: The Motion Picture* and *STAR TREK II: The Wrath of Khan*, the Imperial Race is rarely seen outside Klingon-dominated space.

Once the decision is made, roll 3D10 and add 40 for each attribute except LUC and PSI. Apply the appropriate racial modifiers from the chart according to which type of Klingon you choose to become. For LUC and PSI, roll percentile dice and apply the racial modifiers. In all cases, any score that finishes as zero or below is raised to one.

Finally, roll percentile dice once and divide by two to determine the number of bonus points available. These bonus points may be added to any attribute (except PSI) to raise it, with certain restrictions. No attribute may be increased above 99 with bonus points. Also, no attribute may have more than 30 points added to it.

This completes the determination of character attributes. These scores do not change by normal means during the game, though the gamemaster may alter them as a result of accident or extraordinary things that happen during the course of an adventure. The characters thus created are the best individuals the Klingon Imperial Fleet has to offer — the weak of mind and body simply don't survive the screening process.

Unlike Federation characters, Klingon characters at this stage are about 12 years old (Terran years). Klingons mature earlier and age faster than humans, and their training as warriors begins at birth. These facts will further affect the character generation process, as we shall see.

KLINGON RACIAL MODIFIERS / ATTRIBUTES

	STR	END	INT	DEX	CHA	LUC	PSI
Imperial Race	+10	—	—	+5	-30	-40	-60
/Human fusion	+10	+5	—	—	-20	-40	-50
/Romulan fusion	+10	+10	—	—	-10	-40	-40

GIVEN NAMES AND LINENAMES

Klingons have a given name, and if they belong to a line (see below), a linename. A child's given name can begin with any letter. At maturity (10 years) the initial changes, depending on the career path chosen. Navy names begin with K, Marine with M, and the civilian services (academic and bureaucratic) with A.

Names are often shortened and nicknames are at least as common as among humans. There is apparently sex differentiation, but what sounds "feminine" or "Masculine" in Klingonaese is not often apparent to human ears, and no hard rule can be established.

The linenames bear a prefix indicating personal status. In ascending order these are:

NO PREFIX - A youth who has yet to do anything noteworthy.

"tai"		
"vestai"		
"Sutai"		
"zantai"		
"epetai"		

Any serving ship's officer would be *tai*, or perhaps *vestai* if highly placed. A captain would be *sutai*, possibly *zantai* if he had done something very famous or distinguished. An admiral would be *zantai* certainly. *Epetai* is very rare, and would never be applied (except as mockery) to anyone under the age of 50. The full name is thus written as "Kang zantai-Dvistrill" or "Loanth Lassenti" in childhood.

Lineless children have the number of their House (orphanage) as a surname until maturity. After that they have no surname.

The Klingon lines are more than just families, less than the great dynasties of Earth's history. They are perhaps best thought of as networks of mutual obligation and support. Klingon society is not easy to survive in, and loners stand very little chance.

Lines do not normally feud, though it is not unheard of, but a war between lines usually weakens both to the point of destruction. Rather, they act to secure positive advantages for their members, within the (shifty and unpredictable) limits set by Klingon society as a whole.

Lines tend to expand, through births and occasional adoptions. There is a point at which the line is so large that one's obligations bring a diminished return — especially if one's parent had many offspring with more-or-less equal claim on his favors. At such a time, one or more members will become line-founders, changing their linenames and striking out on their own. Many, perhaps most, founders fail, because one's first act is usually something foolishly bold to establish the name in the Empire's eye. Still, the potential founder is respected, even by the line he leaves.

An Informal Guide to the Klingon Empire

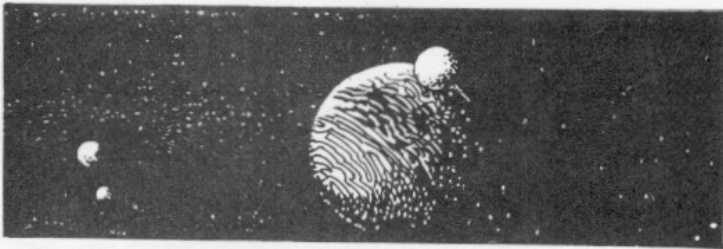

Players whose characters are Marine personnel (Combat Troops specialty area) will most likely have given names beginning with the initial "M". Most others coming out of the character creation system are Naval personnel, and would have given names starting with "K". (Captains Kang and Koloth are examples.)

Very few player characters would be lineless, though some may have once been orphans who were later adopted by some line. A lineless player is at an ENORMOUS handicap in terms of advancement and dealings with bureaucracy, and the gamemaster should adjust the character's fortunes accordingly. A very few highly placed characters may wish to try starting their own line. (No one below the rank of Ship Captain should be able to attempt this.) Starting a line is an uphill battle, and the Empire will take no notice of such until the new line or its founder distinguishes the line by some act of value to the Empire.

Players may choose linenames for their characters. There are many, many lines, but it would not be uncommon for more than one Klingon on a ship to be a member of the same line. Most line obligations go up-rank, not down. Therefore, even a line-brother would not presume upon line affiliation too much. One would not betray a line-brother — unless of course by doing so one could attain such power as to stave off retaliation by other family members. Generally, the safest way of improving one's status within the line is to outlive those with more status.

Characters start with linename prefixes appropriate to their position and status, as determined by the gamemaster using the above notes as guidelines. A player character may earn a more exalted name-prefix as a result of activities during the game. Generally, such improvement of status would come as the result of a general history of accomplishment, rather than for one or two especially noteworthy actions.

There are certain advantages for a young Klingon if he/she is born into (or, in rare cases, adopted into) a prominent and/or powerful line. It is best if line affiliations are worked out by gamemasters and players in advance, using the background material on lines provided above. If desired, however, the following table can be used to determine if a player character will be from an important line. Roll 1D10 on the following table for line affiliation information.

1D10 ROLL LINE AFFILIATION REMARKS

- 1 Character is of a line that is in disfavor with the Emperor or other powerful figure. 10 point penalty to all rolls for assignment, graduation, etc. during character creation procedure, and to all Administration, Bribery or CHA rolls when dealing with Klingons of other lines.

- 2 - 3 Character is of an undistinguished and somewhat disreputable line. 5 point penalty during character creation only.
- 4 - 7 Character is of an established but not especially notable line. No modifiers applied.
- 8 - 9 Character is of a known and well-thought-of line. 5 point bonus as above during character creation only.
- 0 Character is of a powerful and wealthy line. 10 point bonus as above during character creation and campaign play.

Penalties and bonuses assessed because of line affiliation are in addition to those listed as die modifiers in charts that follow. Gamemasters are, of course, free to modify these changes as desired to reflect personal preference, game situations, etc. Also, gamemasters may wish to use line affiliation as an adventure springboard, especially in the case of line founders, disreputable lines, and powerful lines.

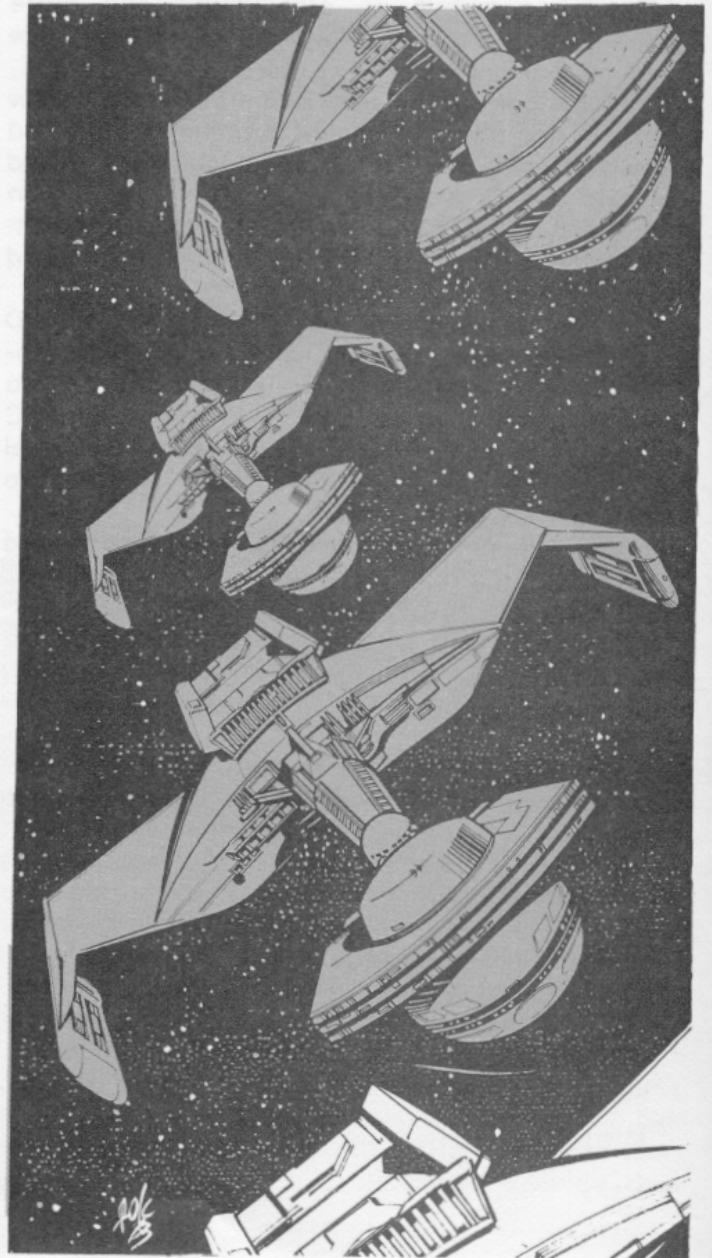

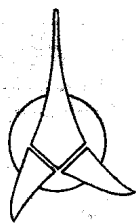

Imperial Klingon Expeditionary Forces
 Imperial Navy
 Sector Naval Garrison
 Exploration/Colonization Fleet
 Merchant/Courier Fleet
 Imperial Starbase Duty
 Security Risk Notation
 Passed
 Favorable Sec Notation
 Imperial Comm.

CADET CRUISE

1st Cruise									
2nd Cruise									
3rd Cruise									
4th Cruise									
5th Cruise									
6th Cruise									

Command School?

SERVICE EXPERIENCE

1st Term										
2nd Term										
3rd Term										
4th Term										
5th Term										
6th Term										
7th Term										
8th Term										
9th Term										

Term Length

CHARACTER	
PLAYER	18
Star Fleet	AGE
RACE	SEX
TITLE	16
LINENAME	
LINE STATUS	15
SPECIALTY AREA	14
CURRENT ASSIGNMENT	13
Marksmanship (modern)	
To Hit Modern	12
Personal Combat (unarmed)	
To Hit H-T-H	11

STR	END	INT	DEX	CHA	LUC	PSI
-----	-----	-----	-----	-----	-----	-----

- | | | |
|------------------------------|---------------------------|-----------------------------|
| Administration | Klingon Law. | Small Vessel Piloting . . . |
| Artistic Ability | Lang. | St. Cmbt. Tac./Str. |
| Atmosphere Craft Pilot. | Leadership. | St. Comm. Proc. |
| Astron./Astroph. | Life Sup. Tech. | St. Engrg. (General) . . . |
| Botany | Marks (Arch.) | Starship Helm Op. |
| Bribery | Mechanical Eng. | Starship Navigation . . . |
| Carousing. | Medicine | Starship Security. |
| Commun. Sys. Tech. | Negot./Diplomacy. | Starship Sensors. |
| Comp. Arch. | Personal Wpn. Tech. | Starship Services. |
| Computer Operation . . . | Prs. Comb. (Ar.) | Streetwise |
| Computer Tech. | Physical Chem. | Surveillance |
| Def. Shield Tech. | Physics | Swimming and Diving. . . |
| Electronics Tech. | Planetary Ecology . . . | Trans. Op. Proc. |
| Env. Suit Operations . . . | Planetary Survival . . . | Trans. Systems Tech. . . |
| Federation History . . . | Psych. | Vocal Music |
| Federation Law. | Rac. Clt./His. | Trivia |
| Forgery | Ship's Weaponry Tech. . . | Value Estimation. |
| Gaming | Shuttlecraft Pilot. | Water Vehicle Op. |
| Geology. | Shutt. Sys. Tech. | Warp Drive Tech. |
| Grav. Veh. Operation . . . | Sm. Eq. Sys. Tech. | Zero-G Operations. |
| Interrogation | Small Unit Tactics. | Zoology. |
| Instruction. | Small Vessel Engineering | Mining |
| Inst. Music | | |
| Klingon History | | |

18
17
16
15
14
13
12
11
10
9
8
7
6
5
4
3
2
1

PRE-ACADEMY

Like Star Fleet, the Klingon Imperial Fleet maintains an academy for young officer candidates. Here, those able to meet the rigorous admissions standards are trained to lead. Unlike their Federation counterparts, however, the students of the Imperial Klingon Star Academy begin their training at age 12. Those admitted to the Academy have been carefully watched and screened since birth, and show special aptitude for leadership — while maintaining a healthy respect for existing authority!

Those who are not up to the stringent warrior standards of the Empire never reach the Academy. Klingon defectives are destroyed at birth, or as early as defects which would make them a burden to the Empire are detected. Most of those who survive are not intelligent, strong or fast enough to make good leaders. These are funnelled into other forms of military service. The unfortunates who are not suited for any military duty are trained as farmers, tradesmen, or other jobs marking them as second-class citizens.

Those who ARE suitable are trained early in use of weapons and the martial arts. For this reason, Klingon youth tend to have more skill in this area before Academy induction than do Federation youth. This is reflected in the fact that the martial skills are represented as a separate pre-Academy skill list, with equal emphasis required in this area.

A character makes a number of pre-Academy skill rolls equal to 1/10 the character's INT attribute score (round down). Pre-Academy skills are chosen from the three lists given below.

Each time a skill is chosen, roll 1D10+5 for the number of skill points gained in that area. Any skill may be chosen more than once to build that skill up further. Any skill in which a specific area must be chosen (like languages or trivia skills) must be specified at this time.

At least 1/3 of the skill rolls must be made on each table, divided as evenly as possible. For example, a person with an INT score of 74 has seven rolls to make. He must make at least two rolls on each table, with the remaining roll (of his total 7) taken on any list of his choosing.

Unlike the system in the basic game, there is no provision for a character to START the Academy as an M.D. at a more advanced age. The administration of medical care is controlled by the military hierarchy. A character may LEARN some medicine in the pre-Academy procedure, but he/she receives no FORMAL training before entering the Academy and being assigned to learn medicine. There are likewise no automatic promotions for medical personnel. Medicine is considered an unfit profession for a warrior; honorable only for women and cripples. Nonetheless, the need for qualified medical personnel leads the hierarchy to assign a number of able-bodied males to this area — like it or not.

A few Klingon women, surprisingly enough, DO attend the Academy if they meet the standards. The Empire does not believe in wasting resources, and

sees talented women as such. Women, however, are not trained in the important areas of leadership, but are restricted to the sciences, medicine, engineering and communications.

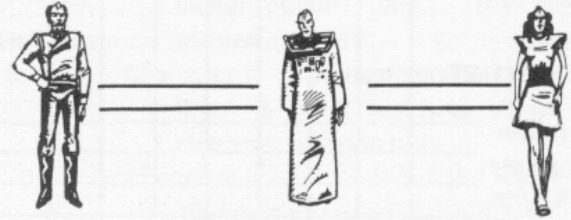

KLINGON PRE-ACADEMY SKILL LISTS

PERSONAL DEVELOPMENT

- Administration
- Artistic Ability
- Bribery
- Carousing
- Gaming
- Instruction
- Instrumental Music (instrument)
- Languages (language)
- Leadership
- Planetary Survival
- Streetwise
- Trivia (category)
- Vocal Music

MARTIAL SKILLS

- Marksmanship (archaic) (weapon)
- Marksmanship (modern)
- Personal Combat (armed) (weapon)
- Personal Combat (unarmed)
- Small Unit Tactics

EDUCATION BACKGROUND

- Astronomy/Astrophysics
- Atmosphere Craft Pilot
- Botany
- Computer Operation
- Klingon History
- Klingon Law
- Geology
- Ground Vehicle Operation
- Medicine (Klingon)
- Physical Chemistry
- Physics
- Psychology (Klingon)
- Water Vehicle Operation
- Zoology

Once pre-Academy skills are determined, the character is ready to enter the Imperial Klingon Star Academy for four years, starting at age 12 (Terran years). The passage of years should be kept track of by the player, as it will determine the character's age at the start of the game.

During the four years, the character (now referred to as an officer "candidate" officially and as "wretched scum" by the faculty) is subjected to strict discipline and complete indoctrination in those skills and abilities deemed by the High Command as necessary to a Klingon naval officer. A set of basic skills is taught to all candidates — the Academy's general education requirements — resulting in the addition of the following amounts to any existing skills possessed:

- Administration (10)
- Astronomy/Astrophysics (10)
- Computer Operation (10)
- Interrogation (10)
- Klingon Histroy (10)
- Klingon Law (10)
- Languages (Galacta) (40)
- Languages (any) (10)
- Leadership (10)
- Marksmanship (modern) (30)
- Personal Combat (armed) (weapon) (20)
- Personal Combat (unarmed) (30)

(NOTE: "Galacta" is the Federation standard language — similar in structure and content to 20th Century English. All Klingon officers have a working knowledge of this language, though many non-commissioned officers and enlisted personnel speak nothing but Klingonese. The Klingon word referring to their common language is "*Klingonaase*".)

The candidate is also placed through a series of aptitude and placement tests at this time to determine what type of training he/she is best suited to perform. Practically speaking, the selection of such training often depends as much on the needs of the Empire at that moment as the results of the tests. The player is here accorded a privilege the character is denied — that of selecting his own life's work.

The player chooses an area of specialty from those listed below, based on the requirements of the job he/she is aiming for. A character who is to be a chief engineer would choose engineering, for example, while a medical officer would pick medicine and a security officer would choose security. Those preparing to be first officer or commander of a star vessel could come from any specialty area except sciences,

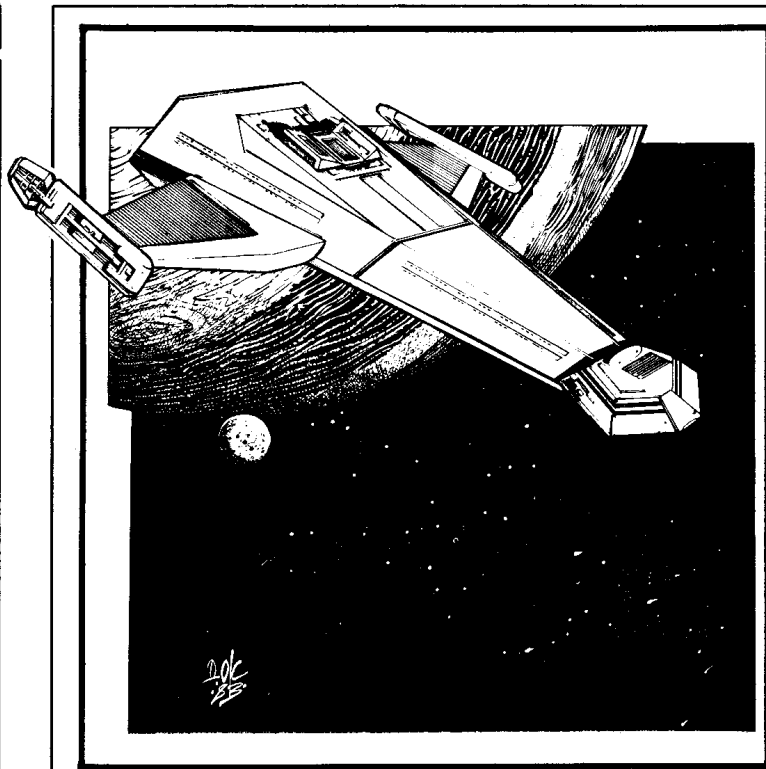

medicine or security, with navigation/helm, weapons/defense and combat troops preferred. No females may aspire to any position higher than department head in sciences, medicine, navigation/helm or communications, and no woman may hold a command or first officer position! (DESIGNERS' NOTE: Don't blame us — blame the Klingons! In the Empire, it's still a man's galaxy...) Because of the restrictions applied to women in the Empire, it is quite permissible for a female player to have a male character!

Please note the differences in emphasis between Federation specialty areas and the closest Klingon counterparts. Navigation and helm duties are not that different on Klingon ships, and these areas of specialization are combined at the Imperial Star Academy. Science officers are not as important as in the UFP, and they tend to be more specialized and less powerful politically.

The specialty area designated "security" is different than the Federation security area. Imperial Klingon Security is a sort of "secret police", reminiscent of the Gestapo of Nazi Germany on Earth. Their primary concerns are with interrogation, internal security, and surveillance. Guarding and actual "muscle" operations are handled by combat troops under the guidance of Security. Though nominally under the orders of the ship's captain, a ship's security department is the eyes and ears of the Empire, and often the chief of security wields more actual clout than the captain!

Combat troops leaders trained at the Academy are Klingon Marine personnel trained to lead and control ground troops and to act as guards and landing force leaders. The control of a ship's troop complement is vitally important to the officers, and the leader of such is in a position to play the security department against other departments — and perhaps against the captain — if he commands the loyalty of his forces.

As larger Klingon ships often have weapons and defense systems controlled by weapons officers directly, this is organized here as a separate specialty area. This is a favored position for ambitious young Klingons, especially those not devious enough for security or physically tough enough for combat duties.

Communications department encompasses most ship's menial services such as food preparation, fabrication, etc. All communications officers are fluent in Galacta, though it is sometimes to their advantage when dealing with Federation ships to not REVEAL the extent of their knowledge. This is a favored position for female officers, as it is more prestigious than medicine or sciences because of its position on the bridge.

Under each department below is a list of skills and skill points gained during the four years at the Academy in each specialty. The candidate gains these skill points in addition to any he/she already has.

In addition, a character gains 10 skill rolls on any combination of skills desired (including repeated rolls on the same skill), as listed in the master chart of skills for Klingon officers. These rolls (1D10 each) may or may not be in the specialty area, as the player desires.

For every 10 points (or portion thereof) over 50 in the character's INT score, the character may take one EXTRA roll (of 1D10) in any skill FROM THE SPECIALTY AREA. Thus, a character with an INT score of 74 would get 3 extra rolls.

Skills should be chosen in a way that moves the character toward having the skills necessary to do a good job in his/her job. Gamemasters should require characters to have basic competence in these areas, but should encourage some diversification to "round out" a character as well. Players and gamemasters should feel free to think up imaginative details about why players ended up with certain skills, and to "personalize" characters. For example, suppose Kravt, who is preparing to captain a battlecruiser, decides to take a skill roll on Vocal Music and rolls a 2. Perhaps he is unaware of his lack of ability in that area, and tends to break out in an old Klingon war ballad at times while on the bridge — and he gets offended and surly if his crew doesn't sing along and compliment him on his powerful voice! Touches like this make characters much more fun to play!

Once the skills from the Academy years are chosen the character is ready to prove his/her worthiness to serve the Empire on a one-year cadet cruise.

IMPERIAL KLINGON STAR ACADEMY SPECIALIZATION AREAS & SKILLS

SCIENCES

Astronomy/Astrophysics (20)
 Computer Operation (10)
 Environmental Suit Operations (10)
 Starship Sensors (20)
 Any other sciences skills (Botany, Comp. Archeology, Geology, Phys. Chemistry, Physics, Planetary Ecology, Zoology) (80 — in any combination, but at least two must be 10 or above . . .)

ENGINEERING

Computer Technology (20)
 Deflector Shield Technology (10)
 Electronics Technology (10)
 Environmental Suit Operations (10)
 Life Support Systems Technology (10)
 Mechanical Engineering (20)
 Personal Weapons Technology (20)
 Physics (10)
 Ships's Weaponry Technology (20)
 Starship Engineering (general) (30)
 Starship Sensors (10)
 Transporter Operational Procedures (10)
 Transporter Systems Technology (20)
 Warp Drive Technology (25)

SECURITY

Bribery (20)
 Federation Law (10)
 Gaming (20)
 Interrogation (30)
 Klingon Law (20)
 Marksmanship (modern) (20)
 Negotiation/Diplomacy (15)
 Personal Combat (unarmed) (20)
 Personal Weapons Technology (10)
 Psychology (Klingon) (10)
 Shuttlecraft Pilot (20)
 Small Unit Tactics (20)
 Starship Security (30)
 Surveillance (20)
 Zero-G Operations (10)

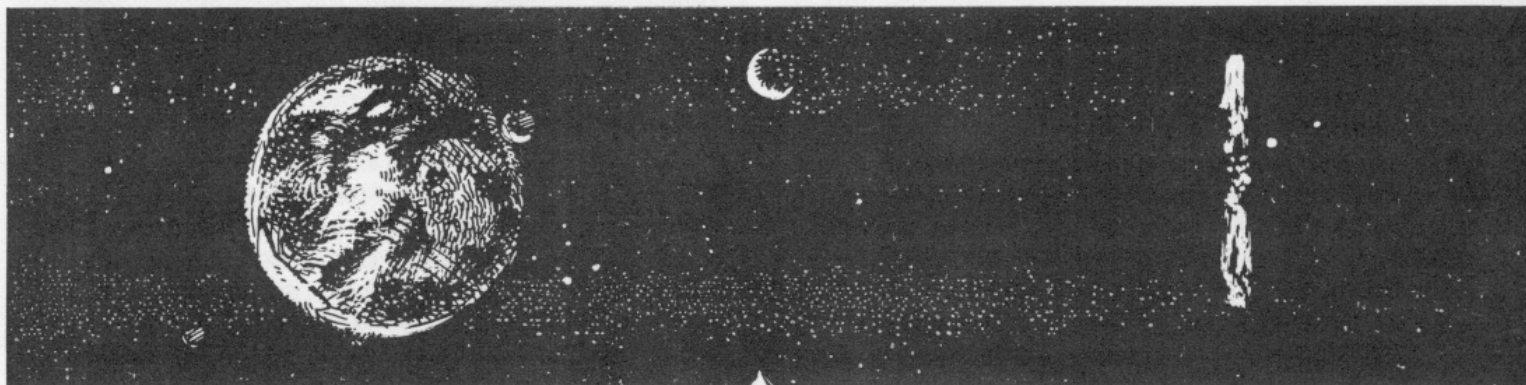

COMBAT TROOPS

Carousing (20)
Environmental Suit Operations (25)
Gaming (10)
Ground Vehicle Operation (20)
Interrogation (10)
Languages (10) (any)
Leadership (30)
Marksmanship (archaic) (weapon) (10)
Marksmanship (modern) (30)
Personal Combat (armed) (weapon) (20)
Personal Combat (unarmed) (30)
Personal Weapons Technology (10)
Planetary Survival (20)
Small Unit Tactics (20)
Streetwise (20)
Zero-G Operations (30)

MEDICINE

Botany (10)
Env. Suit Operations (10)
Interrogation (25)
Life Support Systems Tech. (10)
Medicine (Klingon) (40)
Medicine (any non-Klingon) (10)
Psychology (Klingon) (10)
Starship Security (10)
Starship Sensors (20)
Zoology (10)

NAVIGATION/HELM

Astronomy/Astrophysics (25)
Computer Operation (10)
Computer Technology (10)
Electronics Technology (10)
Starship Helm Operations (40)
Starship Navigation (40)
Starship Sensors (20)
Warp Drive Technology (15)

WEAPONS/DEFENSE

Computer Operation (10)
Computer Technology (10)
Deflector Shield Technology (20)
Electronics Technology (20)
Ship's Weaponry Technology (30)
Starship Combat Tactics/Strategy (20)
Starship Engineering (general) (15)
Starship Sensors (25)
Transporter Operational Procedures (20)

COMMUNICATIONS

Communications Systems Technology (30)
Computer Operation (15)
Electronics Technology (10)
Languages (Galacta) (20)
Languages (any other) (15)
Small Equipment Systems Technology (10)
Starship Communications Procedures (30)
Starship Sensors (20)
Starship Services (20)
Transporter Operational Procedures (10)

ALL DEPARTMENTS

10 skill rolls (1D10) in any skills.
1 bonus skill roll for every 10 points (or fraction thereof) over 50 in INT attribute score.
(These must be taken on skills listed under specialty area above. . .)

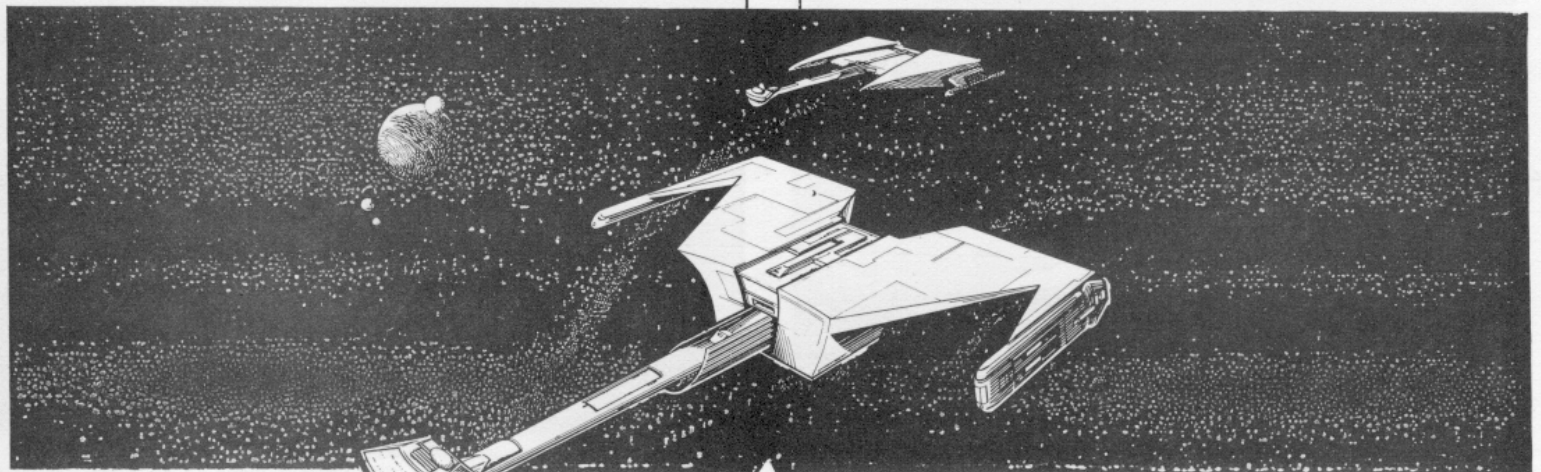

CADET CRUISE

Upon completing training and indoctrination at the Imperial Star Academy, the candidate is sent on a one-year assignment in space, where his performance is carefully monitored by his superior officers and by agents of Klingon Imperial Security acting for the Academy. During this cruise, the officer-in-training carries the rank of Midshipman. Unlike Federation practice, Imperial cadet Midshipmen do indeed exert useful authority on such cruises. (How else could a Midshipman maintain the respect of the crew?)

Often, a candidate may be required to take two or more of these tours-of-duty. Sometimes this indicates marginal performance, but more often the candidate has done or said something that sounded faintly seditious to Security officials. In such a case, a note is made in the candidate's record — a note that may haunt him/her for the rest of his professional career.

Each time a candidate fails a cadet cruise results roll, he/she must attempt a standard saving roll against the character's CHA score. If the roll is successful, no permanent blot appears on the character's record. If the roll fails, however, the character has a PERMANENT security risk notation on his/her record. Each note of this type applies a 10-point penalty against ALL saving rolls on Administration, CHA, and Bribery when dealing with the Klingon government or superior officers. Too many such marks can permanently cripple a character's ability to increase in rank, get good assignments, etc.

Bribery can play an important part in a character's advancement, if the character is good at it. A character with a low Bribery skill level, however, might be better off to wait until it can be raised, as bribery within the advancement structure can be dangerous to the uninitiated's standing. See the list of modifiers for each step for specific bribery procedures.

If a candidate fails the cadet cruise, the cruise procedure is repeated (with a 10 point penalty on the results roll — security has a special eye on you now...). If a character fails more than 3 or 4 cruises, and gets several security risk notations, the player and gamemaster may agree to scrap the character (keeping the records for use as a non-player later, perhaps) and start again. This is recommended to keep player characters from starting out with "one foot in the (political) grave," as it were.

When a character passes a cadet cruise, she/he is promoted to Ensign. The character also gains 5 rolls (1D10) for any skills of her/his choosing at this time. No skills are gained by candidates who FAIL a cruise. Each cruise adds one year to the character's age.

Follow the procedure below for determining the results of cadet cruises:

CADET CRUISE ASSIGNMENT

Roll percentile dice against the following table, applying die modifiers as applicable below, to determine in what type of assignment the character will serve for the cadet cruise.

less than 25	Imperial Klingon Expeditionary Forces
26 - 40	Imperial Navy
41 - 65	Sector Naval Garrison
66 - 80	Exploration/Colonization Fleet
81+	Merchant/Courier Fleet

DIE MODIFIERS

-20	Character is of the Imperial Race
-10	LUC 40+
-5	LUC 35-39
+5	LUC 20 or less
-10	INT 70+
-5	INT 60-69
+10	Failed to pass last cruise

Bribery attempt (save on Bribery skill) allowed if desired, AFTER assignment roll is made. Successful bribe moves character up one step on assignment table (and adds 5 to Bribery skill level). Unsuccessful attempt moves character down one step (and adds 2 to Bribery skill level anyway...).



CADET CRUISE RESULTS

Roll percentile dice and apply the modifiers as below to discover the results of the character's cadet cruise.

less than 05	Passed with imperial commendation (immediate promotion one grade; -20 on first post-Academy assignment roll)
06 - 15	Passed with favorable security notation (-10 on first post-Academy assignment roll)
16-60	Passed
60+	Failed (Save vs. CHA necessary to avoid permanent security risk notation – repeat cruise procedure)

DIE MODIFIERS

Imperial Klingon Expeditionary Forces	-20
Imperial Navy	-15
Sector Naval Garrison	-10
Exploration/Colonization Fleet	+10
Merchant/Courier Fleet	+20
LUC 40+	-10
LUC 35-39	-5
LUC 20 or less	+5
Second (or later) cruise	+10
Successful Administration skill roll	-10

A bribery attempt may be made BEFORE rolling results, at the player's option. A successful bribe means the character AUTOMATICALLY passes the cruise (but without any chance for special commendations), and gains 5 points on the Bribery skill level. A bribery attempt that FAILS, however, means the candidate AUTOMATICALLY fails the cruise and AUTOMATICALLY receives a security risk notation. (A failed bribery attempt still adds 2 to the Bribery skill level...)

A character who receives a security risk notation suffers a PERMANENT penalty of 10 points to all saving rolls against the Bribery and Administration skills, or against the CHA attribute, when such rolls are made in dealings with the Klingon government or Klingon superior officers having access to the character's file.

This penalty is cumulative, adding 10 points to the penalty per risk notation. Security risk notations may be wiped out at some future time by the gamemaster if the character involved has an exemplary service record or performs some special service to the Empire. They are also removed if the character finishes the cruise procedure with an Imperial Commendation or a favorable security notation.

CADET CRUISE SKILLS

A character gains 5 rolls (1D10) on any skill areas of his/her choosing when passing the cadet cruise.

The character is automatically promoted to Ensign (or one grade higher, if finishing with an Imperial Commendation).

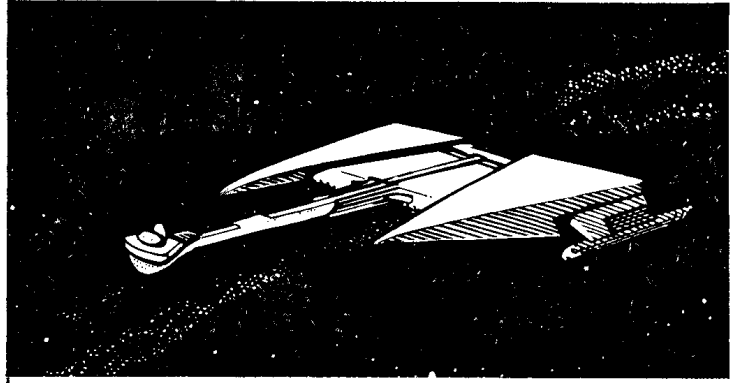

COMMAND SCHOOL

Characters who are to be department heads or top command personnel are required to attend Command School for two years following their cadet cruise. During this time, they are indoctrinated and educated further in the skills that are important to a Klingon military leader. Only ship captains, first officers, and those preparing for department head positions in engineering, security, combat troops, navigation/helm, or weapons/defense attend Command School. At this time, the young officers are watched closely by Security.

At Command School, a character receives the following skill points automatically:

- Administration (25)
- Interrogation (20)
- Klingon Law (20)
- Federation Law (10)
- Leadership (30)
- Starship Combat Tactics/Strategy (20)
- Starship Security (20)

Graduates of Command School are automatically raised one grade in rank at the end of the two-year period.

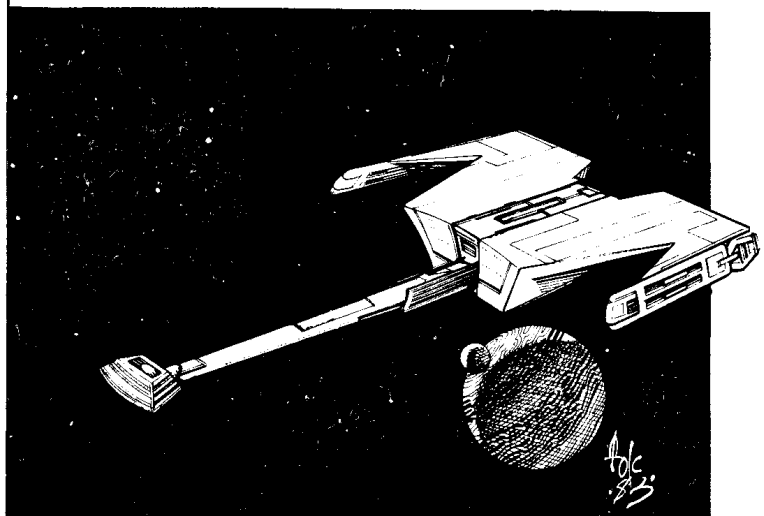

POST ACADEMY EXPERIENCE

The post-Academy experience procedure, like its counterpart in the basic game for Federation characters, determines how many years of service a character has put in prior to entering a campaign at a certain level. Generally speaking, a character who starts a campaign with a higher rank or position will be more experienced (and older) than an officer in a less lofty post. There is plenty of room for luck and initiative to get an officer up through the ranks faster, however. Klingon officer characters tend to rise through the ranks faster than their Federation counterparts (and fall just as fast, if they aren't careful...). This is just as well, as Klingons have a shorter lifespan than humans, and suffer aging effects sooner.

Before the game, player and gamemaster have decided what position and rank the character will fill in the campaign. This information now influences the number of years spent in prior service (and skills gained during this service.)

First, the player should determine how many terms of service have gone between the completion of the cadet cruise (or Command School) and the beginning of the adventure campaign. Use the following procedure for determining terms served:

TERMS SERVED

Roll 1D10, subtract 1, and divide by two (round down — minimum roll allowed is 1). Add and/or subtract the following modifiers to determine the number of terms served.

Character preparing to command a ship (Ship Captain or First Officer)	+2 terms
Character preparing to be a dept. head	+1 term
LUC 40+	-1 term
LUC 20 or less	+1 term
Character enters campaign as an Ensign	-1 term
Lt. J.G. or Lt.	no modifier
Lt. Cmdr. or Cmdr.	+1 term
Ship Captain	+2 terms
Admiral or above	+3 terms
Character enters campaign as dept. head or command personnel on ship of the Imperial Klingon Expeditionary Forces	+1 term

TERM LENGTH AND ASSIGNMENT

Each "term" served is on a different ship or in a different location. Young Klingon officers are kept moving around a lot, partly to give them a variety of experience and partly to prevent them from developing a strong organization of their own anywhere. Thus, the term length for young officers is from 1 to 4 years (as opposed to 1 to 5 years for Federation personnel). The following tables will allow the player to determine

what type of assignment the character had for each term, and how long he/she stayed on that assignment.

Much of this background is to fill in the character's background for role-playing. Players and gamemasters are encouraged to elaborate on this information as much as possible, adding details as desired. Perhaps a character who had been in a nowhere job for a year or two suddenly is assigned to the Imperial Klingon Expeditionary Forces. That character may have distinguished himself in some manner to rate a choice assignment. On the other hand, a well-placed officer who is suddenly sent to a Merchant/Courier ship may have aroused the suspicions of a superior officer, who had him transferred to a less strategic post where he would be out of the way. Fill in the details! It makes playing the character that much more fun.

This information is also used to determine how old the character will be when the actual campaign starts. All Klingon children enter military training/indoctrination at age 12. The Academy adds 4 years to this, plus one year for each cadet cruise taken. If the character went to Command School, add 2 more years. This should give you the character's age at the time service as an officer begins. At the end of the next section, you can add the character's years of prior service to that total to find out how old your character is as the game begins. This age is important in determining your final skill rolls.

Complete the following procedure as detailed by the charts:

Roll 1D10, subtract 1, and divide by two (round down — minimum result is 1) to determine the length in years of each term of service. Then, roll on the following table to determine where the term was served.

Imperial Klingon Expeditionary Forces	10 or less
Imperial Navy	11-30
Sector Naval Garrison	31-50
Exploration/Colonization Fleet	51-70
Merchant/Courier Fleet	71-85
Imperial Starbase duty	86-00

DIE MODIFIERS

INT 70+	-10
INT 60-69	-5
LUC 40+	-10
LUC 20 or less	+5
Graduated with Imperial Commenda- tion (first assignment only)	-20
Graduated with favorable security no- tation (first assignment only)	-10



SERVICE SKILL ROLLS

Add up the number of years of service from all terms (not including Academy, cadet cruises, or Command School) to determine the number of years spent in service. The character gains 1 skill roll (1D10) per two years spent in service, with the following additions:

INT 70+	2 extra rolls
INT 60-69	1 extra roll
LUC 40+	1 extra roll
per 2 yrs. service	
Exp. Forces	1 extra roll
per yr. Imperial	1 extra roll Streetwise
Starbase duty	or Gaming
per addl. cadet	1 extra roll Streetwise,
cruise beyond 1st	Gaming, or Carousing

The character is now ready to enter the adventure campaign. Record the character information on a character record sheet.

CHARACTER AGING

Since Klingons have a shorter life span than humans, they reach a critical age and begin to risk aging effects quicker than most Federation characters. For each 10 full years a character has lived beyond the critical age, roll 1D10 for each of the STR, END and DEX attributes and reduce that attribute by the rolled amount. The year-by-year aging LUC saving roll may be made by players as detailed in the main book once the campaign has begun.

The critical age varies between Imperial Race Klingons and Human/Klingon fusions, as follows:

IMPERIAL RACE	Critical age 40
HUMAN/KLINGON FUSION	Critical age 45
ROMULAN/KLINGON FUSION	Critical age 60

RANKS, POSITIONS, AND TITLES IN THE EMPIRE

For a full discussion of Imperial ranks, positions and titles, consult the appropriate part of the Historical Update section later in this book. Klingon usages differ somewhat, and a player should be somewhat familiar with this material before proceeding to fill out his/her character's background.

In the character creation data given in this section, Federation equivalent ranks have been used, rather than their (largely unpronounceable) *Klingonaase* (Klingonese) equivalents. As noted in the basic game character creation section, "rank" differs from "position", and the two should not be confused. "Lieutenant" is a rank — "Communications Officer" is a position. The title-conscious Klingons require that players also be able to distinguish a "title" from "rank" or "position". In some cases, a "title" is the same as the "position". (For example, "Chief Navigator", "Security Chief", "Sciences Specialist", etc.) In other cases, it may differ. For instance, the Chief Medical Officer (position) aboard a D-7 battlecruiser would be at least the Klingon equivalent of a Lieutenant (rank), but would likely be addressed as "Doctor" (title).

Marine titles and ranks apply to all in the Combat Troops specialty area. Rank names differ slightly in Klingonese, but the same system of Federation equivalents is used here to avoid confusion. Personnel assigned to Security, even if assigned to soldierly duties, are still considered Naval personnel. Combat Troops specialists may be assigned to Security duties, but retain their status as Marines.

Skills and Skill Descriptions

Most of the skills available to the Klingon character are the same as those available to the Federation character. Some, however, are new while still others are established skills requiring new definition for Klingon player characters.

The following is a full alphabetical list of skills available for choosing during the Klingon character creation sequence, followed by explanations on those skills not already covered in the basic rulebook, and skills requiring new explanations or clarification.

SKILL AREAS – ALPHABETICAL LISTING KLINGON PLAYER CHARACTERS

Administration
Atmosphere Craft Pilot
Artistic Ability (form)
Astronomy/Astrophysics
Botany
Bribery
Carousing
Communications Systems Technology
Comparative Archeology (race)
Computer Operation
Computer Technology
Deflector Shield Technology
Electronics Technology
Environmental Suit Operations
Federation History
Federation Law
Gaming
Geology
Ground Vehicle Operation
Klingon History
Klingon Law
Instruction
Interrogation
Instrumental Music (instrument)
Languages (language)
Leadership
Life Support Technology
Marksmanship (archaic)
Marksmanship (modern)
Mechanical Engineering
Medicine (race)
Negotiation/Diplomacy

Personal Combat (armed) (weapon)
Personal Combat (unarmed)
Physical Chemistry
Physics
Planetary Ecology
Planetary Survival
Psychology (race)
Racial Culture/History (race)
Ships' Weaponry Technology
Shuttlecraft Pilot
Shuttlecraft Systems Technology
Small Equipment Systems Technology
Small Unit Tactics
Starship Combat Tactics/Strategy
Starship Communications Procedures
Starship Engineering (general)
Starship Helm Operation
Starship Navigation
Starship Security
Starship Sensors
Starship Services
Streetwise
Surveillance
Swimming/Diving
Transporter Operational Procedures
Transporter Systems Technology
Vocal Music
Trivia (category)
Water Vehicle Operation
Warp Drive Technology
Zero-G Operations
Zoology

ARTISTIC ABILITY: Klingon art runs to the martial themes, and is mostly of the realistic school. Klingon artisans are not respected as warriors are, but are tolerated if their talents are used to glorify the warrior/conqueror theme in some manner. Most Empire artisans, however, are members of servitor races.

BRIBERY: Skill at subtle negotiation of bribes, kickbacks and other quasi-legal and illegal payoffs. This skill comes into play whenever a character must make a secret payoff or find a corruptible individual in a hierarchy who can be "bought". Failure of a bribery saving roll means that the attempt is detected by the authorities, either because the bribe was not subtle enough, or the character being bribed proved not to be so corruptible after all and turned in the person offering the bribe.

FEDERATION HISTORY: This skill, for Klingon characters, represents the somewhat slanted version of Federation history taught in Klingon schools. If a character has opportunity (outside the Empire, or through experience) to learn about the Federation view of history, this is learned as a separate skill under the Trivia category.

GAMING: Including knowledge of the basic forms of Klingon chess (*klin zha*), a skill few warriors are without. The Klingon form of chess is very important in Klingon history and politics, especially in reference to "*komerex zha*", or "the perpetual game" of society, which all individuals play. *Klin zha* grandmasters are highly regarded, and the game has status in the Empire that chess lacks in Human culture.

KLINGON HISTORY: Again, this is the Klingon "official" view of their own history. It is mostly accurate, but colored by the Klingon world-view.

KLINGON LAW: Klingon civil and criminal law shifts much more rapidly than Federation equivalents, due to the shifting nature of Klingon politics. This category does not include the internal laws and traditions of individual lines. A Klingon knows his own line's rules completely. If he/she has opportunity to learn the laws and traditions of another line, they must be learned as a Trivia skill category.

INTERROGATION: Skill governing the questioning of prisoners, sometimes under duress or torture. A saving roll is used here to successfully gain information from a prisoner. If the roll succeeds, the victim gets a saving roll try on the INT score (if the interrogator is using trickery) or the END score (if duress or torture is used). If the victim's roll succeeds, no information is given. If not, the questioner gets a significant piece of information, at the gamemaster's option. The gamemaster may give bonuses (or penalties) to victims based on the importance of the information, training, and temperament. For instance, a trained Star Fleet security officer would be less likely to break under interrogation than a civilian. A starship captain six times decorated for bravery would likely hold out longer than a rookie sciences specialist.

NOTE: If torture is used, it is possible that the victim may die before giving up a secret. If the questioner makes a successful roll, and the victim fails the END save by more than 20 points, the victim passes out, taking 2D10 of wound-type damage in the process. (This damage can be cut in half if the victim is attended by support devices and/or medical personnel who make a successful save on the appropriate Medicine skill.) The victim may be immediately revived (if the damage doesn't kill him, or bring him below his unconsciousness level), but the process must begin again with another save on the Interrogation skill level.

Also, each torture attempt does 1D10 wound damage (or half that, with attendance of a physician as above) to the victim no matter what the outcome. Thus, a victim's END continues to drop under continued torture, making it all the more likely that the victim will pass out or possibly die under duress before talking. It is possible to administer medical aid to raise END before continuing torture.

Please note that Vulcans know mental techniques to "turn off" pain. Thus, it is impossible to torture information out of a Vulcan.

ALL TECHNOLOGY AND PROCEDURES SKILLS: All skills of this type are effectively halved for operating similar equipment of an unfamiliar race. Thus, a Klingon with a 48 skill level in Starship Communication Procedures would have only a 24 skill level when operating equipment in a Federation vessel. This does





not apply to marksmanship skills, as most personal weapons are not hard to point and fire, and officers of both the UFP and Klingon Empire are given familiarization courses in each others' personal weapons.

The penalty to skill levels is negated if the character can make a saving roll in the appropriate language, or has had time to become familiar with the controls either through EXTENSIVE trial and error, or by having someone who reads the language or is of the appropriate race show him/her.

SURVEILLANCE: Skill in seeing without being seen, either personally or through technological devices such as hidden microphones and cameras. A successful surveillance roll will allow a character to follow another without being spotted (though the target may get an INT save in some cases).

A character may also wish to attempt a save in situations where a plot or coup is suspected (as a Klingon captain suspecting a plan to take his position). In such cases, the roll is made secretly by the GAMEMASTER when the character requests it. The exact results of the roll are not revealed to the player. Instead, if the roll is successful, the player will "hear a rumor" if there is a plot, and perhaps gain some useful information. If the roll fails, the player learns nothing. (On a particularly bad roll, the player may hear FALSE rumors...) If there is no plot, the player hears nothing either way (except on a very bad roll, where the player might be told lies...).

Gamemasters may wish to make secret rolls for some characters, even when not requested. These should be made when someone with an established surveillance network (such as a Klingon ship captain or security chief) might accidentally pick up on important information they are unaware of. If such a roll succeeds, the gamemaster may give a bit of information to the character. (Again, false information may

be given for spectacular failures of saving rolls.)

Proper use of secret surveillance skill rolls serves to keep Klingon players, particularly those in high positions, properly paranoid. Note that attempts to detect suspected surveillance and/or defeat known surveillance efforts are made by rolling saving throws against this skill as well.

SWIMMING AND DIVING: This skill area covers the techniques involved in swimming and diving (not skin or SCUBA diving, but including competition diving). A character with a minimum skill level of 5 in this area is considered to be able to swim or at least float well enough to survive for a short period of time in water over his/her head without drowning. A minimum skill level of 10 implies the ability to swim as recreation without fear of drowning under normal circumstances.

Those with skill levels in excess of 20 are considered experienced at swimming and diving at the level of an enthusiast. A skill level saving throw in this area may be required if a character is required to perform some unusual feat of swimming skill, such as rescuing a drowning person, swimming long distances or under adverse conditions such as fast currents or extremely cold water, competing in water athletics, etc.

As an addition to the rules, all graduates of Star Fleet Academy or the Klingon Imperial Star Academy are granted a minimum skill level of 5 in this area. All player characters except Vulcans and Caitians may choose this skill as part of the PERSONAL DEVELOPMENT skill tables available for pre-academy or early life experience. (Vulcans come from a dry planet with little free-standing water, and Caitians are not comfortable with swimming or large bodies of water. While both races are capable of learning to swim, it is unlikely they would have learned to do so in early life, if they grew up in their native cultures.)

Physiology and Medical Aid

KLINGON PHYSIOLOGY

Due to their different physiology, note the following adjustments to be made to game functions for Klingons:

IMPERIAL RACE Klingons take +1 point damage per die from projectile weapons such as bullets, and +2 points of damage per die from edged weapons such as daggers and swords.

FUSIONS (Human or Romulan) take +1 point damage per die from edged weapons only.

NEURAL DRUGS (stimulants, sedatives, neural paralyzers, etc.) add +1 point per die of effect. In addition, **INHALED** drugs of this type will also take effect 10% faster in both Imperial Race and fusions.

Saving roll vs. agonizer effects is at -40 for Klingons of both types (as opposed to -50 as given in basic rules for humans and others).

The following adjustments are made to stun damage taken by Klingons. These adjustments are **OPTIONAL** for use with Klingon non-player characters in Federation-based campaigns, but are encouraged for Klingon player characters.

	HUMANS	FUSIONS	IMPERIALS
STUN	75	60	50
(graze)	25	20	20
HEAVY STUN	120	100	80
(graze)	40	35	30

Klingons perspire very little. An extensive net of capillaries just under the skin acts as an efficient heat exchanger. The specific heat capacity of thin Klingon blood is also high. They are, as a result, less affected by heat — especially wet heat — and more by cold than most Federation races. (Klingons and Vulcans are comfortable at about the same temperature, but the Klingon would find the Vulcan environment unpleasantly dry!)

The black wrist-to-ankle garments that Klingons wear when visiting Federation installations contain a layer of vapor barrier. A human wearing such a suit would shortly be swimming in sweat.

An Informal Guide to the Klingon Empire

The standard healing rates for Human and Romulan fusion Klingons is the same as the normal healing rate specified in the basic rulebook — 1/10 normal END score per half hour for "temporary" damage and 1/20 (round down) normal END per day for wound damage. For Imperial Race Klingons, healing for "temporary" damage is as above, but round UP when figuring healing rate for wound damage. (For example, if an Imperial Race Klingon has an END of 50, divide that by 20 for a result of 2 1/2. This rounds UP to 3 points of healing per day, where a human would round DOWN to only 2 points per day.)

MEDICAL PHILOSOPHY

Many people (Federation citizens mostly!) seem to think that Klingon medicine is very primitive. This is

not true, as is evidenced by the many breakthroughs in the genetic sciences that are only now being duplicated by Federation (and Romulan) scientists. The major difference between the medical care wielded by the two powers is the concept of *triage* (simply, the judgement made by a doctor as regards the order of treatment of severely wounded or ill patients). Whereas Federation doctors treat severe trauma patients on a worst wounded—first treated basis, Klingon doctors use an entirely different criterion in this decision. The Klingon doctor must decide whether it would be cost effective to repair an individual. If it would be less costly to let an individual die than to train a replacement, the patient would not be treated. On the other hand, if a patient's knowledge and skill is termed invaluable, no costs would be spared to save that patient's life.

Klingon doctors (and their patients) also do not worry much about pain. This is reflected in that Klingon doctors have fewer mild anesthetics and pain killers available to them. Klingons are not, however, adverse to using heavy pain blocking drugs to counter crippling pain. If a pain killer is required to place an otherwise incapacitated man back on the job, a doctor will not hesitate to use it.

Likewise, Klingons do not worry as much about how a repair looks as how well it functions. Plastic surgery for cosmetic purposes is unheard of, but its use in espionage is well known (witness Arne Darvin in the episode *The Trouble with Tribbles*). If major surgery leaves a scar, this is readily accepted. Klingons wear their scars proudly.

KLINGON MEDICAL EQUIPMENT

MEDICAL POUCH: Unlike Federation doctors, Klingon medics have only one medical pouch, containing everything the doctor is likely to need. The medical pouch contains the following: one foam dressing applicator, one vital signs reader, one organic suture, two laser scalpels (beam diameter carried varies according to the perceived needs of the medical officer), one pneumatic hypodermic, two spare pressure cylinders, and nine medicine cylinders, including light and medium sedatives, light and medium stimulants, a general purpose poison antidote, a pain blocking drug, a pain enhancing drug, a truth drug, and an END booster. These items will be explained in greater detail in this section.

When a character with Medicine skill of at least 10 uses the Klingon medical pouch, treat it as the Federation issue medical pouch as regards the **EMERGENCY FIRST AID SAVING ROLL** in the basic rule book. Note also that Klingons do not have any functional equivalent of the smaller Federation medical field kit. This is not to say that Federation medics are under-equipped. Rather, in situations where a Federation team's medical officer would carry only the small field

kit, an equivalent Klingon team would likely have no medical officer along at all!

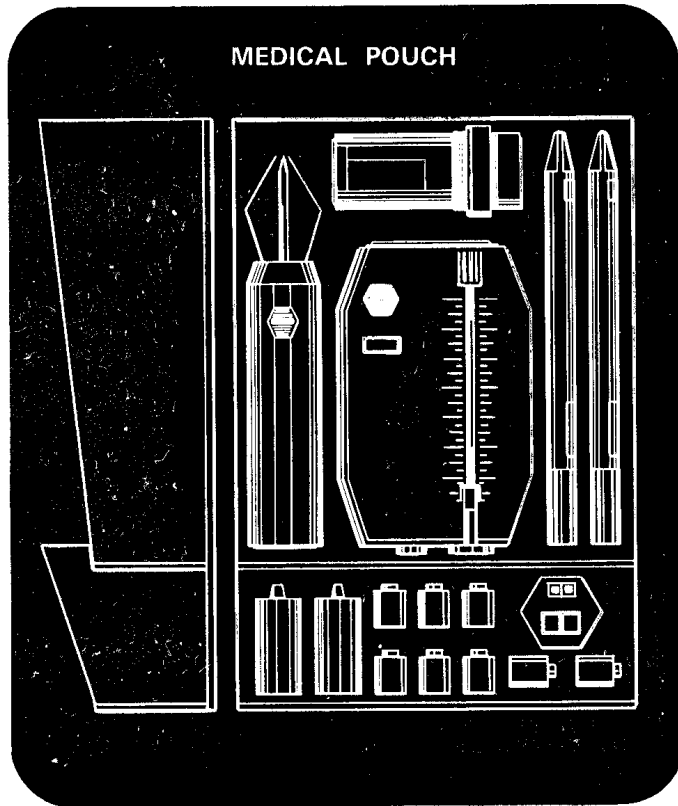

BIOSUPPORT & MONITOR SYSTEM: This device looks much like a large box with sensor cables, intravenous tubes, and one large cable running out of it. The cable is tipped with the standard data cart connector, and this requires the Biosupport & Monitor System be plugged into the data cart slot on the Portable Computing Recorder (see the EQUIPMENT section). These two units can be used to monitor vital signs and supply support suggestions. The Biosupport section also contains a large supply of drugs, which the unit can administer automatically in an emergency. (This feature can be overridden by the operator at any stage.) This device has several uses, from the support of massive-trauma patients to the support of prisoners undergoing traumatic torture.

DIAGNOSTIC / SUPPORT TABLE & PANELS: These are similar in many respects to the Federation versions, the basic differences being that the display is totally programmable (unlike the vertical slide scales of the Federation panel). The side panels not only provide a means of programming and/or retrieving medical data into the system, but also provide a large supply of drugs for the maintenance of the patient.

These tables are also found in the operating room. In addition to the tables (and mounted to the wall between the tables) are surgical benches. These also contain a data retrieval system, and have two instrument trays that swing out for use. These instrument trays include both modern instruments and emergency backups (bladed scalpels, etc.).

FOAM DRESSING APPLICATOR: This is different from the Federation Spray Dressing (see MEDICAL GLOSSARY in the basic rule book) only in appearance. When the unit is empty, screw cap disposable refills are available.

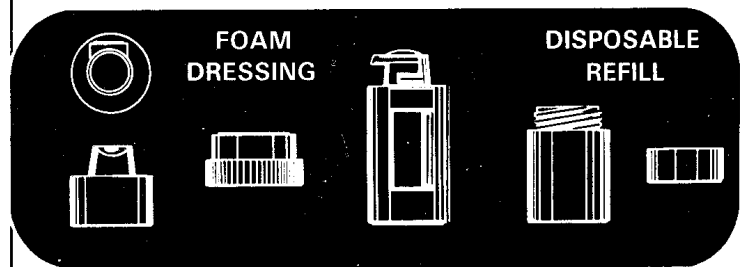

LASER SCALPELS: The laser scalpel is long and pencil-shaped, with a rechargeable power supply plugging in the end. (A full charge will last about three hours of continuous use.) There are seven beam diameters available: 000, 00, 0, 1, 2, 3, and 5. A Medicine skill of 40+ is necessary to perform surgery.

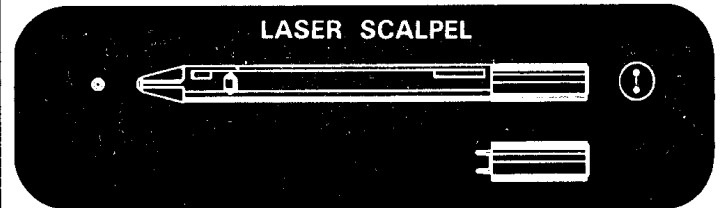

ORGANIC SUTURE: Unlike the Federation Protoplaser, the Klingons use an Organic Suture to close wounds. This device extrudes a very fine organic fiber, which is then literally knitted into the wound by the two small arms (somewhat as a spider spins a web) to seal the wound. In the back is a small fluid reservoir that holds enough fluid to last about thirty minutes of continued use. A Medicine skill of 20+ is required for most first-aid type applications, but for major surgery involving major blood vessels and delicate work, a Medicine skill of 40+ is necessary.

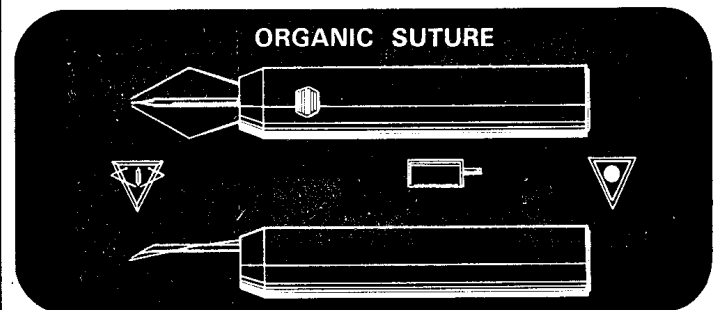

PNEUMATIC HYPODERMIC: A flat object shaped somewhat like a bar of soap, the hypodermic has two holes at one end for the insertion of one medicine cylinder, and one air cylinder. At the opposite end is a wide screen which is the injector. The large upper surface consists of a slide for selecting the dosage to be injected, a push-button to inject the medication, and a two digit LED that tells the amount of medicine remaining in the medicine cylinder.

A full medicine cylinder contains 10 units of medicine each. The hypodermic can inject up to two units at a time, but is usually set for one (that being the normal dose). An air cylinder contains enough pressure to give 50 injections, after which time it must be replaced. Anyone with a Medicine Skill of 10+ may safely use the Hypodermic without overdosing the patient.

HYPODERMIC

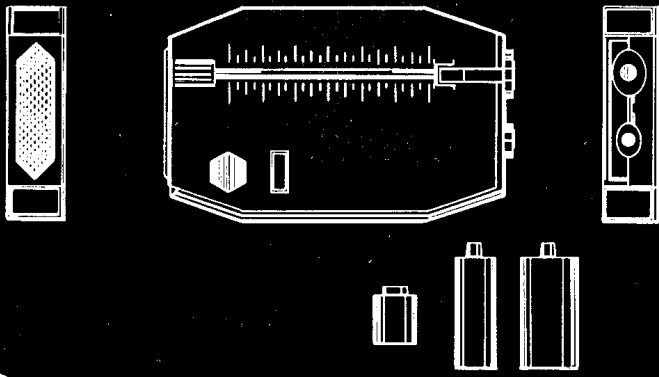

VITAL SIGNS READER: The Vital Signs Reader is a hexagonal shaped object about 20 millimeters across and 12 millimeters thick. On the top surface it has a two digit LED and two control buttons. On the bottom surface is a sensor pad, and on one of the six sides is a recharge socket similar to that on the Laser Scalpel. A full charge on the Vital Signs Reader lasts about 10 hours.

The Vital Signs Reader is not quite as handy to use as the Federation Medical Feinberger. It must be pressed, sensor pad down, against the skin of the patient, and then one or both of the buttons pressed. Pressing the left button reads out the heart rate of the patient, while pressing the right button gives the patient's respiration rate. Pressing both buttons at the same time will give the patient's blood pressure. As it takes a small amount of time to read the vital signs, the device requires one turn before it will give the read-out requested. During this time it must remain pressed against the skin of the patient. Anyone may use the device if they know which button (or buttons) to press.



VITAL
SIGNS
READER

MEDICATION AND DRUGS

Klingon medicines come from two sources. Some have been developed by Klingon researchers over the years, while some have been stolen outright from the

Federation or other sources. For the purposes of the game, it may be assumed that the following drugs (listed and described in the basic rulebook) are available to a Klingon doctor: Light, Medium, and Heavy Stimulants, Light, Medium, and Heavy Sedatives, Tri-ox Compound, Sterilite, Neural Paralyzer, and a number of poison antidotes. In addition to these, several new drugs are available, as follows:

ENDURANCE BOOSTER: This drug adds 4D10 to the patient's END for 1/10 the patient's END in hours. At the end of this time, however, the patient's END will drop to 1/2 its previous level for the same amount of time. If this is below the patient's unconsciousness level, the patient will faint. If this reduces the patient's END below zero, the patient is in danger of dying. (Treat as normal wounding and apply normal first aid rules from the basic rulebook). This drug, despite its dangerous nature, might be given to a crewman or officer who could not be spared from his position at a critical moment. It would allow a person to return to duty (assuming the state of his injuries was not so critical as to suffer more damage from the effort) temporarily.

PAIN BLOCKING DRUG: This drug will block all pain from any wound for a time equal to 3D10 + 10 turns. During this time, the patient will feel no pain, and will never have to make an unconsciousness save. Of course, if the victim's END drops below the unconsciousness level, he will still pass out. If the victim's END is reduced to less than half its original level when the drug wears off, the victim will have to make one unconsciousness save whether damage is received that turn or not. After that point, saves are made as normal. Note that a person under the influence of this drug may not notice being injured further. (Make a secret INT save each time he is hit to see if he notices the injury, unless the injury is obviously visible.) This drug has a side effect, reducing the INT and DEX 2D10 points each during its effect period, thus making it unsuitable for widespread use on combat troops. Certain berserker units of Klingon Marines are believed to use this drug on suicide missions.

PAIN ENHANCING DRUG: This drug magnifies the pain that is felt by the victim. During the time that the drug is active (3D10 + 10 turns), a new unconsciousness save level is set at 3/4 original END. After that time has elapsed, all saves are made at their original level. Use of this drug applies a 20 point penalty to saving rolls for victims attempting to resist torture.

SUGGESTABILITY DRUG: For a time period lasting 1D10 in hours, the victim is very suggestable. Unless a saving roll is made against the character's INT divided by 3 (rounded down), the victim will believe whatever he is told. The gamemaster should assign modifiers to this roll depending on the plausibility of the statement involved. (If the victim is told that his hand is missing when it obviously is not, he will probably not believe this statement ... unless his saving roll is incredibly bad.) The drug *cannot* force a person to take action he/she would ordinarily not take (such

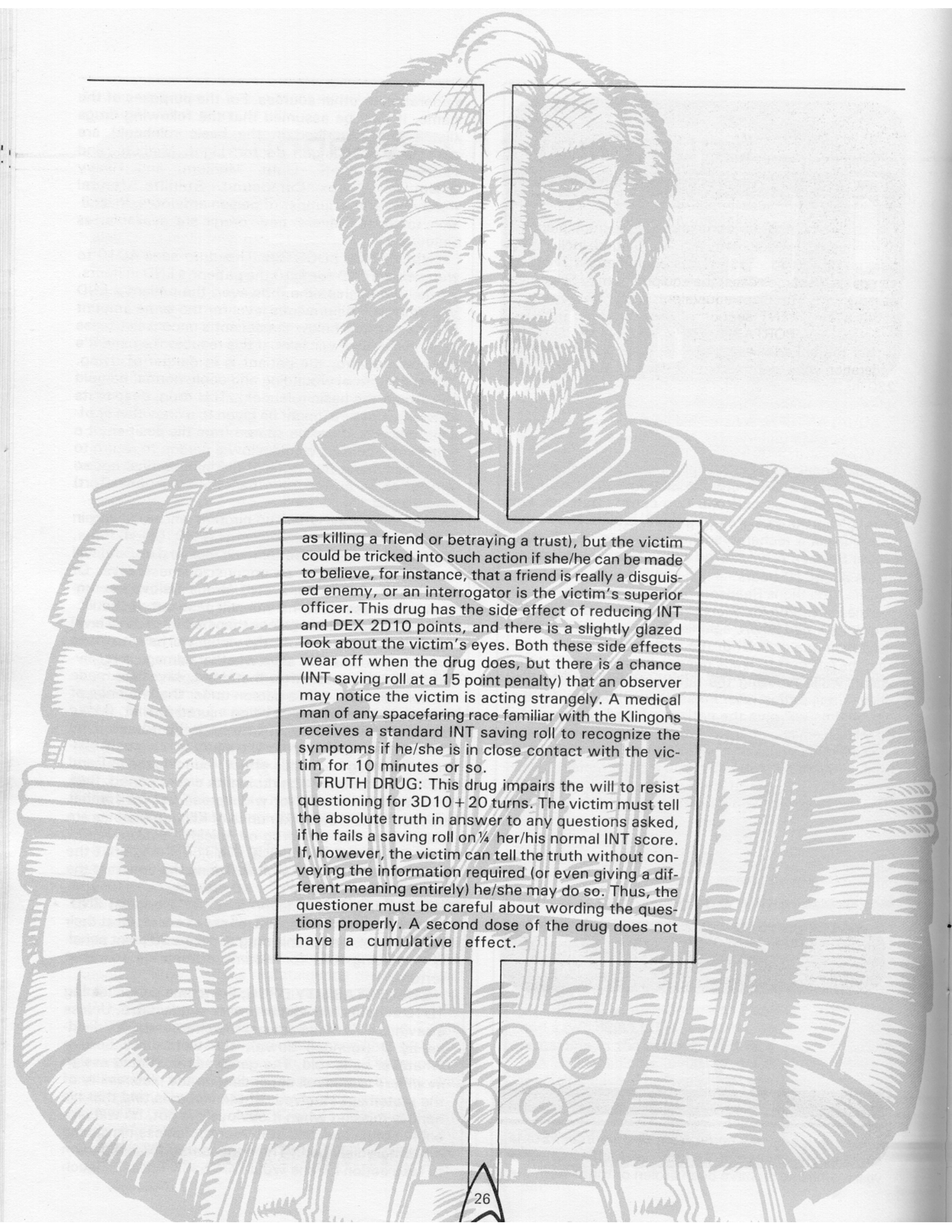

as killing a friend or betraying a trust), but the victim could be tricked into such action if she/he can be made to believe, for instance, that a friend is really a disguised enemy, or an interrogator is the victim's superior officer. This drug has the side effect of reducing INT and DEX 2D10 points, and there is a slightly glazed look about the victim's eyes. Both these side effects wear off when the drug does, but there is a chance (INT saving roll at a 15 point penalty) that an observer may notice the victim is acting strangely. A medical man of any spacefaring race familiar with the Klingons receives a standard INT saving roll to recognize the symptoms if he/she is in close contact with the victim for 10 minutes or so.

TRUTH DRUG: This drug impairs the will to resist questioning for 3D10 + 20 turns. The victim must tell the absolute truth in answer to any questions asked, if he fails a saving roll on $\frac{1}{4}$ her/his normal INT score. If, however, the victim can tell the truth without conveying the information required (or even giving a different meaning entirely) he/she may do so. Thus, the questioner must be careful about wording the questions properly. A second dose of the drug does not have a cumulative effect.

Equipment and Weapons

EQUIPMENT

In this section, description of many common pieces of Klingon issue equipment will be provided, including data on how to incorporate the equipment into your campaign. In some cases, the equipment may be compared to the Star Fleet equivalent; if so, please refer to the EQUIPMENT section of the basic rule book.

ANTIGRAV, PORTABLE: These units are, by nature, similar to the Federation type. They will, as with the Federation units, neutralize up to 100 kilograms (about 220 lbs.) of mass. Again, more than one may be used on more massive items (one per 100 kilograms).

AQUALANTERN: A handheld light source that may be safely used underwater. It will illuminate an area 10 meters cubic.

COMMUNICATOR: A small transceiver to be used by landing parties for person-to-person and person-to-ship communications. Physically, it has a flat case with a T-shaped back, and a red plastic cover. The cover is hinged and flips up (although it is not the antenna, and does not act as the on-off switch as on the Federation communicator). The case is silver in color.

Inside, are three function selection pads and a 3-digit LED type display. Below that are two tell-tales indicating transporter lock-on (left LED) and frequen-

cy jam / scrambler on/off status (right LED). Set between these two LEDs is a triangular speaker grill, and below that is the frequency shift/gain dial. Note that Klingons use a peculiar 12-segment digital LED unlike Federation 7-segment LEDs (like those used in digital watches and calculators).

The communicator can be used both in a person-to-person (over line-of-sight distances) or person-to-ship (in standard orbit, 16,000 miles maximum range) transmissions. The signal may be blocked by atmospheric disturbances, intervening terrain (like mountains), or dense materials. In addition to the normal uses as a transceiver, it may also be used to scan for energy sources up to 500 meters away. This scan only tells the presence of, and not the intensity or nature of, the energy source.

The unit is active at all times, but automatically goes into a "stand-by" mode whenever not in use. This means that the communicator is always open to receive no matter what the circumstances, giving a soft tone when the possessor is being called.

The unit also serves as a lock-on device for transporter operation, much as does the Federation unit. Whenever any transporter device has locked onto a particular unit, the left-hand LED will glow red.

COMPUTER/RECORDER, PORTABLE: The Computer/Recorder is a small (6 cm x 28.5 cm x 11.6 cm)

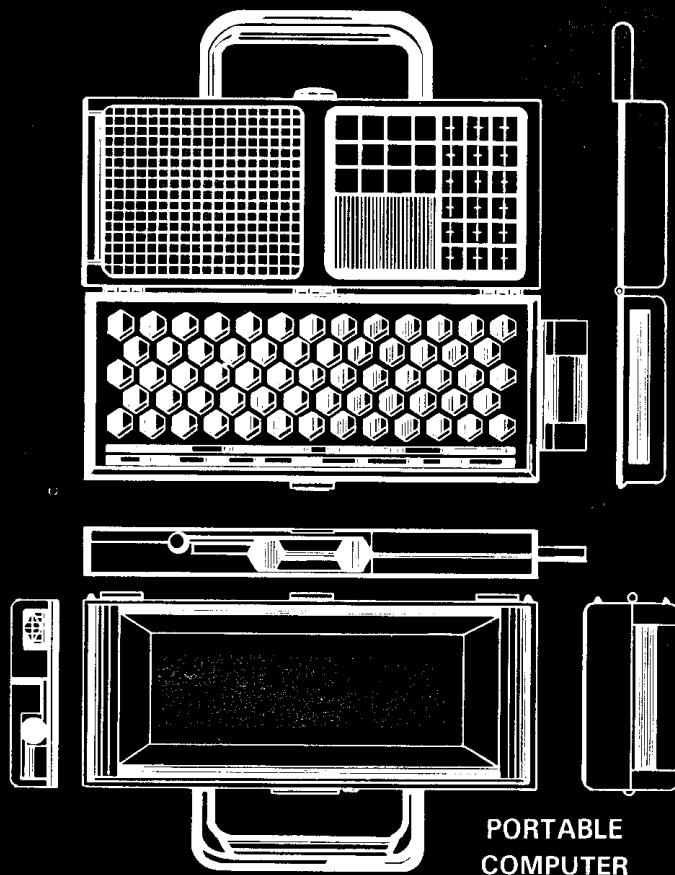
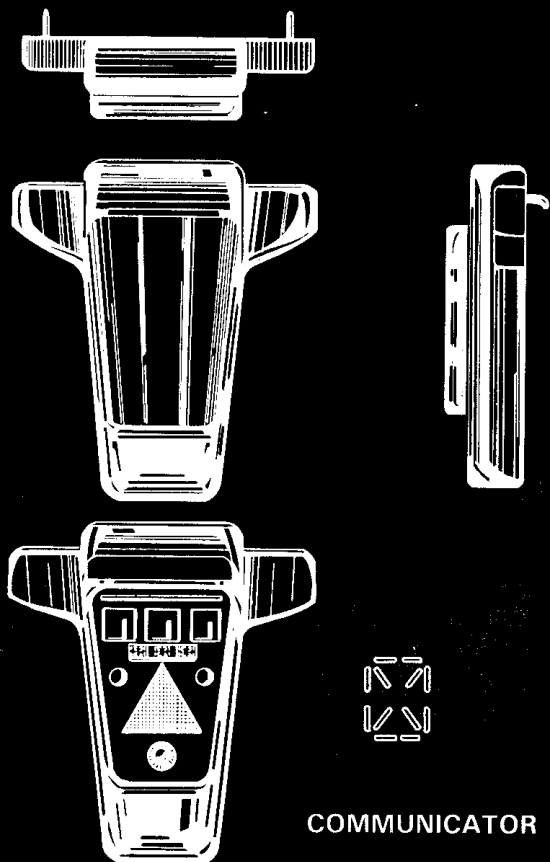

box with a handle on top. It opens to reveal a keyboard on the lower half and two screens on the upper half. The left screen is text only, while the right screen is for graphic applications only. This separation of function allows both to be used at once in some applications. A data cart plugs into an opening at the right; these are the same data carts as are used with any ship's computer. On the end opposite the cart slot (when closed), is a microphone and video lens. The device may be aimed at anything, a button (mounted in front of the handle) depressed, and the machine will record whatever it is aimed at into the data cart. The Computer/Recorder may also be programmed to replay or analyze anything recorded into a data cart.

ENVIRONMENTAL SUIT: This is a "space suit" that maintains a self-contained artificial environment—air, heat, moisture, and pressure—for up to 24 hours. The suit is used whenever maximum protection is required, and can withstand total vacuum, poisonous environments, extreme temperatures (both heat and cold), and higher pressures (up to 5 Klinzai atmospheres). There is also a deluxe suit that provides the same protection, but for a much longer period (1 week). This suit not only provides the environment, but a liquid food supply as well.

The suit looks basically angular in nature, with the helmet being boxlike in shape. On the back is carried a large box-shaped package which houses the atmosphere filters, heater, air conditioner, moisturizer, and water supply. In the deluxe model, the pack (which is somewhat larger) also contains a small amount of liquid food concentrate tasting something like an animal broth.

Operation of the Environmental suit is similar to that of the Federation suits. A skill level of 10 or more in Environmental Suit Operation is necessary to use one. See the EQUIPMENT section of the basic rule book for more about the operation of the Environmental suit.

Unlike the Federation model, the standard Environmental suit is not self-sealing (this being a frill saved only for the officer's deluxe suit). If the suit is torn in vacuum, the victim will die of decompression in $1D10 + 3$ turns unless the suit is patched. (A patch kit is usually carried in a belt pouch.) Poison contamination would take somewhat longer to affect the victim, depending on the intensity of the poison in the atmosphere. Cold or hot environments would not be lethal, but may affect the portion of the character's anatomy that is exposed by the rip. If the character were brought back into a safe environment (ie. a ship's airlock) before the fatal amount of time elapses, only a proportionate amount of damage would be received. Treat the deluxe suit as you would the Federation model as regards rip damage.

FORCE FIELD BOX: This item differs from the Federation version only in appearance. For game purposes, treat it the same as the Federation model (see the EQUIPMENT section of the basic rule book).

I.D. CARD: The Klingon version of the I.D. card is somewhat different than the Federation version. It is somewhat smaller than the Federation card, and is

mounted on a chain which then hangs around the bearer's neck. (This is somewhat reminiscent of the mid-twentieth century "dog-tags" worn by soldiers of the United States.) The I.D. Card is made of a plastic-like material that retains information in much the same way as the Federation card. The chain is so designed that one strand will separate from its attachment point for removal. When the free end is touched back to its attachment point, it will re-attach itself to the card. In all other respects, treat the I.D. card as its Federation equivalent (see the EQUIPMENT section of the basic rulebook).

LIFE SUPPORT MASK: The Klingon Life Support Mask is somewhat larger than the Federation version, both in that it covers the eyes as well as the nose and mouth, and that it has a small (3 inch by 1 ½ inch dia.) cylinder mounted just below the mouth. It can act both as a filter (to filter out mildly toxic gasses), as a portable air supply (the cylinder contains 10 minutes of oxygen), or as a combination of the two. (In a very thin environment, the mask will use oxygen out of the cylinder to bring the outside air to a breathable level. Thus the supply will last proportionately longer.)

MARINE HYPOTHERMIA CAPSULE: This coffin shaped and sized device is basically a cold sleep capsule for the transport of Marine troops to and from an engagement. Each unit contains the necessary equipment for maintaining the life of its inhabitant, but has no external read-outs. At the foot end, however, is a Data Cart Slot Connector to be plugged into the Portable Computing Recorder. This provides the operator with the information and control capabilities needed. 1 out of every 25 persons placed in Klingon cold sleep will not survive the ordeal of "thawing". Thus, roll percentile dice for every person reawakened. A roll of 04 or less indicates death.

UNIVERSAL TRANSLATOR: This is a silver colored device that hangs on the belt, and translates the

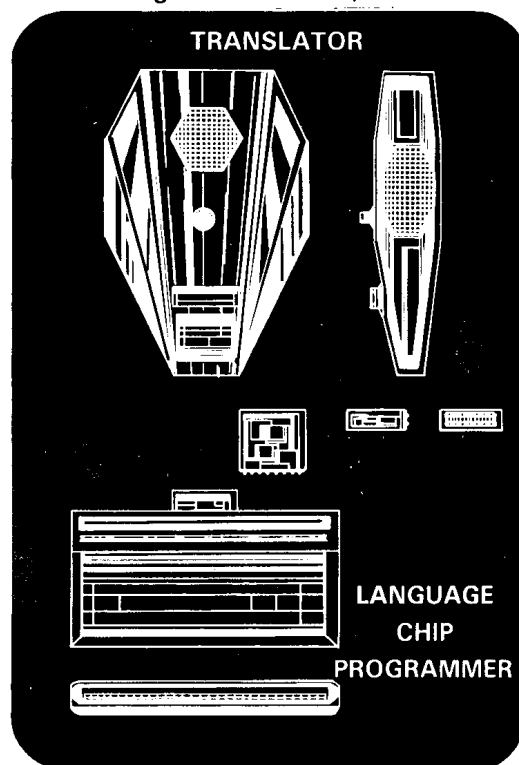

bearer's speech as well as the audiences'. There is a microphone on the front to receive the audiences' speech, and two speakers on either side to broadcast what the bearer says to the audience. Two additional devices are required for the device to be used, a throat-microphone and a small receiving earphone. The throat microphone is adhesively attached to the user's throat, and transmits the user's voice to the translator. As the device translates what the audience says, a signal is transmitted to the earphone. There are no connecting wires between the device and either the microphone or the earphone.

Unlike the Federation Universal Translator, the Klingon device must be individually programmed for the language to be translated. The chip containing the language is programmed through an adapter that plugs

into any data cart slot (either on the portable computer/recorder or the starship's computer). Only one language at a time may be stored on a chip at a time, and a new one must be inserted into the translator to change languages. For totally unknown languages, an analysis by ship's computer must be made before programming a chip. If the culture in question uses any form of radio transmission, such transmissions may be monitored from orbit for 1D10 hours to get the sample needed to create a chip. Otherwise, native speech must be recorded on the site for 1D10 divided by 2 hours and transmitted to the ship for analysis (a process taking 1D10 divided by 2 hours itself) before a chip can be made. Of course, if an unknown language proves to be a variant of some known tongue, the job can be done much faster.

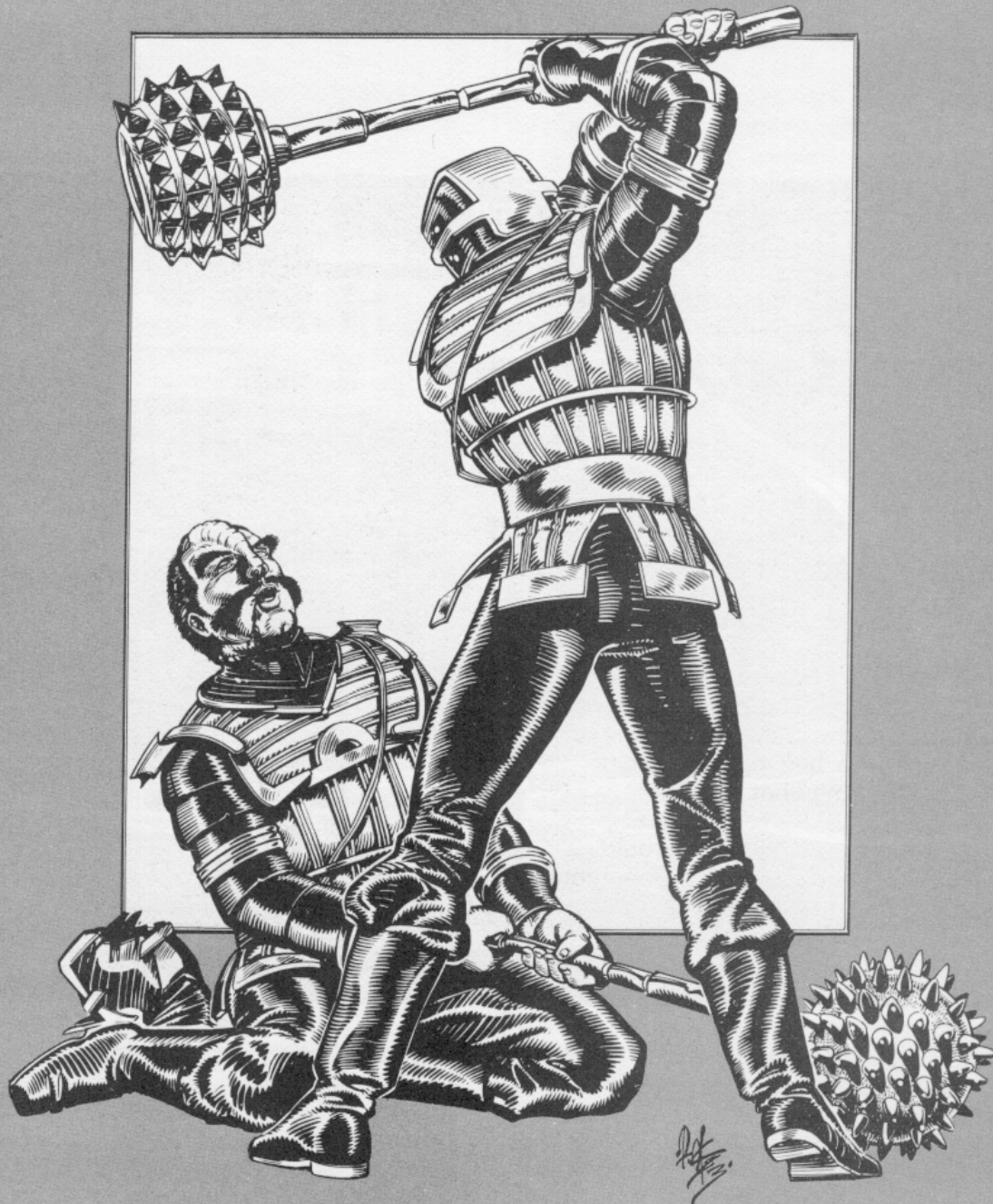

The standard sidearms and common weapons among Klingon starship crews have changed somewhat over the years. In this section, we will discuss the evolution of the hand disruptor and the disruptor rifle as standard Imperial Fleet weapons, as well as the Klingon agonizer.

The early-model disruptor — known popularly as a “sonic disruptor” did indeed emit a tight beam of ultra-high-frequency sound...

An old Star Fleet Academy joke runs approximately:
 KLINGON CAPTAIN - “Surrender, or we shall blast you to atoms with our sonic disruptors!”
 FEDERATION CAPTAIN - “Uh, Captain, sound doesn’t travel in a vacuum.”
 KLINGON CAPTAIN - “Curses, foiled again.”

Actually, the Klingons do possess a sonic-maser weapon, but it is used currently only on liquid-submersibles and by underwater troops. (In gaseous atmospheres, it travels slower than a bullet.)

There are three models of disruptor in use. The oldest version (the Mark I), which is supplied to other races as a “trade item”, is a focussed microwave projector. The more sophisticated versions (Mark II and Mark III), which appeared first as ship’s battery weapons and have been recently refined to personal portability, act to suppress molecular binding forces. They operate in the pulsed mode, causing oscillating stress and contraction in the target.

Both types of weapon produce vibrations, heat and noise. The Klingon term *virid dakaasei* literally means “the shake-it-till-it-falls-apart tool.” (Note that in *klington-aase* there is no distinction between tools and weaponry.)

An Informal Guide to the Klingon Empire

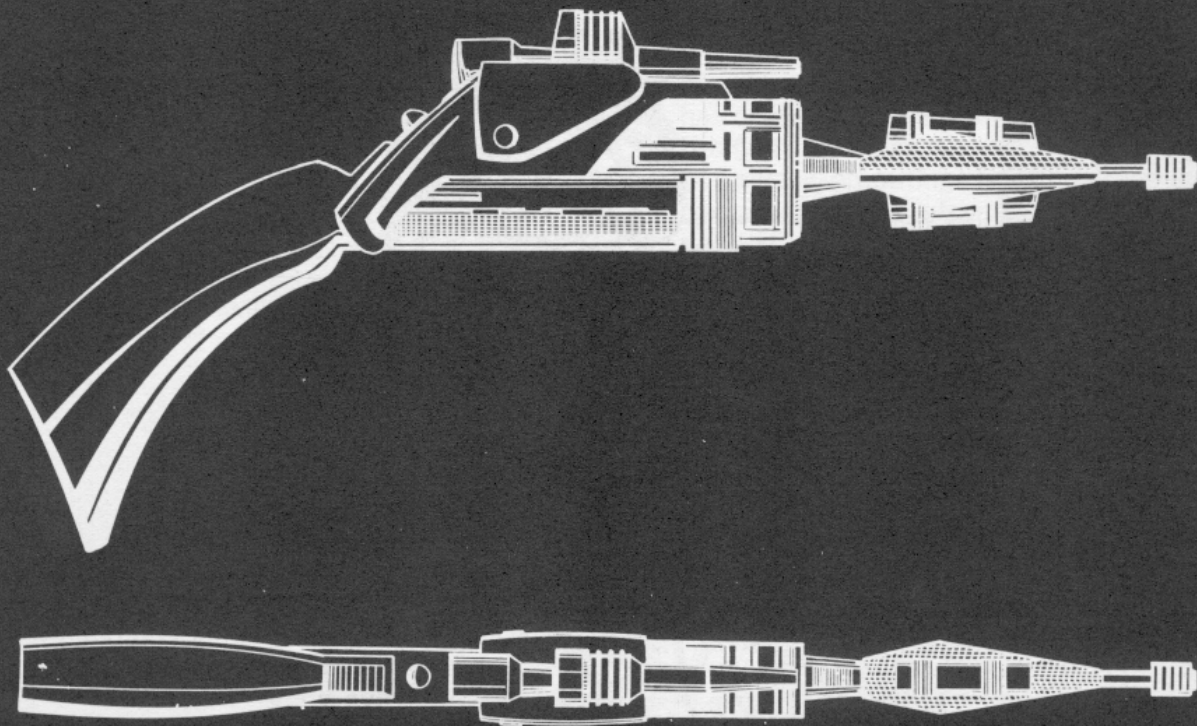

MARK I DISRUPTOR

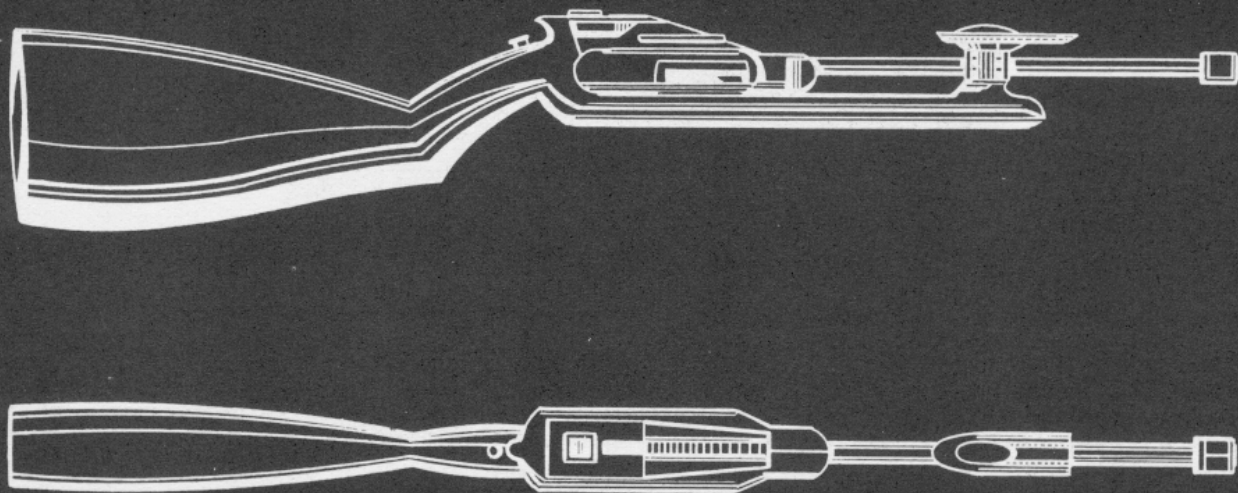

MARK I DISRUPTOR RIFLE

The Mark I disruptor is the Klingon hand weapon traded to the Romulans and Orions, among others, and is often found on the black market even within the Federation. Its capabilities are similar to the Mark II disruptor, but it is a bit clumsier to use and harder to field-repair. The beam exciter cylinder at the base of the barrel must be shielded by small field grids mounted on either side to keep the beam properly focussed. If the weapon is dropped or handled roughly, these grids may be misaligned, resulting in less accuracy.

(In the game, make a LUC save for anyone dropping or banging up a Mark I disruptor. Failure to save means the grids are misaligned. Weapons with misaligned grids fire at all targets as if they were one range class farther away. Thus, a short range shot would be rolled like a medium range attempt, a medium like a long range shot, etc. An extreme range shot would be impossible with a damaged disruptor.

Damaged weapons can have grids realigned by anyone who has a small toolkit and can make a successful save on the Personal Weapons Technology or Small Equipment Systems Technology skill. The repair takes about five minutes.)

The Mark I disrupts and damages the cell structure of living organisms, but does not disintegrate them. If fired at solid objects, it produces vibration and heat, either shattering or melting them, according to their structure and materials.

There is also a disruptor rifle with similar effects but greater range and a larger powerpack, used mostly by ground troops and some security guards. The rifle was a later design, using a different focussing method not practical (at that time) on a pistol model. Thus, it is not as delicate as the pistol, and is tough enough to even be used for parrying without damage (unlike the less rugged Federation-design phaser rifle). It was the advanced focussing method of the rifle design that eventually led to the improved Mark II pistol.

The Mark II was the first hand disruptor to feature the new molecular debonding effect. On standard setting, the Mark II has cellular disruption and/or vibration/heat effects similar to the Mark I. On extreme power setting, however, it is capable of disintegrating a man-size target, though this setting is wasteful of

power and not effective at extreme range. The Mark II does not require the delicate field grids used on the Mark I, and is hence not as delicate. There is no rifle version of the Mark II — the original rifle design continued to be used throughout this period.

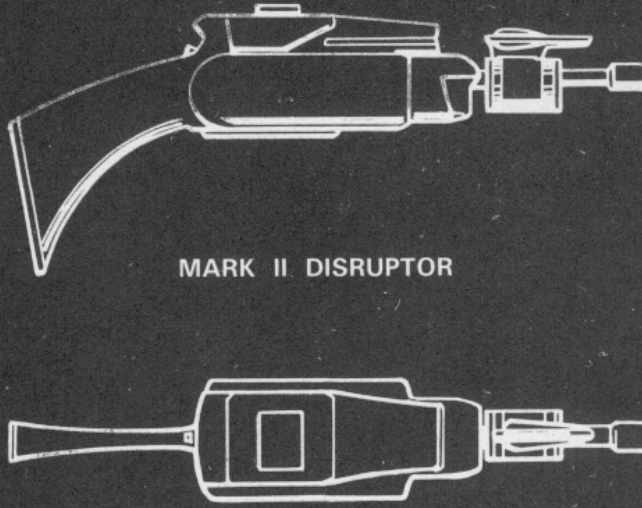

MARK II DISRUPTOR

The Mark III (coming into use about the time of *STAR TREK: The Motion Picture...*) disruptor is just an improved version of the Mark II with greater range and power reserve. The rifle version is created by adding an extension stock (containing a larger power-pack) and a longer beamguide "barrel" (allowing greater accuracy). The Mark III is a bit bulkier than the Mark II, but it is easier to manufacture and repair. It is also capable of disintegration of a man-size target with increased power consumption and no effect at extreme range.

All disruptors use the unique grip-and-firing-stud design of Klingon armsmiths instead of the more familiar trigger. All four fingers of the hand are curled under the grip, with the thumb resting atop the firing stud for activation. Power adjustment for the Mark II and III is accomplished by turning the front ring of the beam exciter cylinder at the base of the barrel.

The capabilities of each type of disruptor are outlined in the following chart, which can be added to the basic weapons chart in the basic book in place of the single set of disruptor stats (for the Mark II, shown in the basic book).

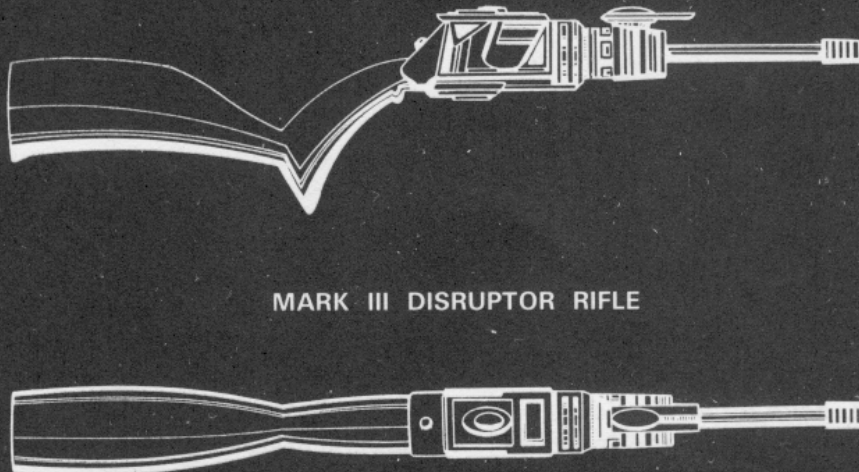

MARK III DISRUPTOR RIFLE

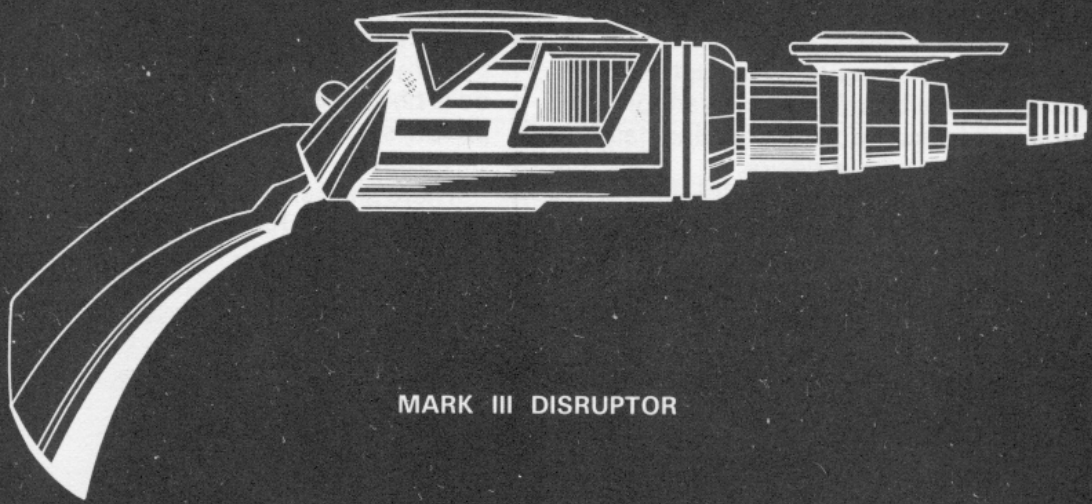
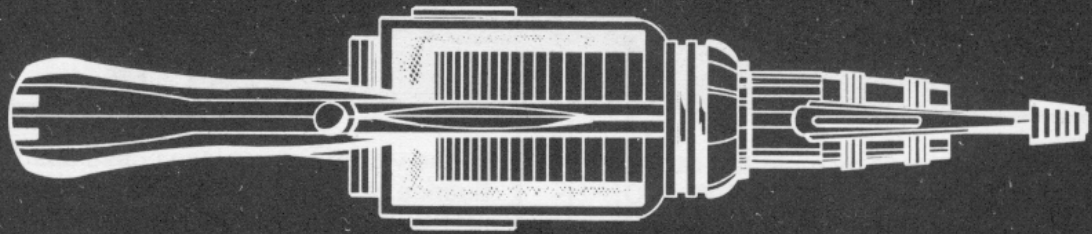

MARK III DISRUPTOR

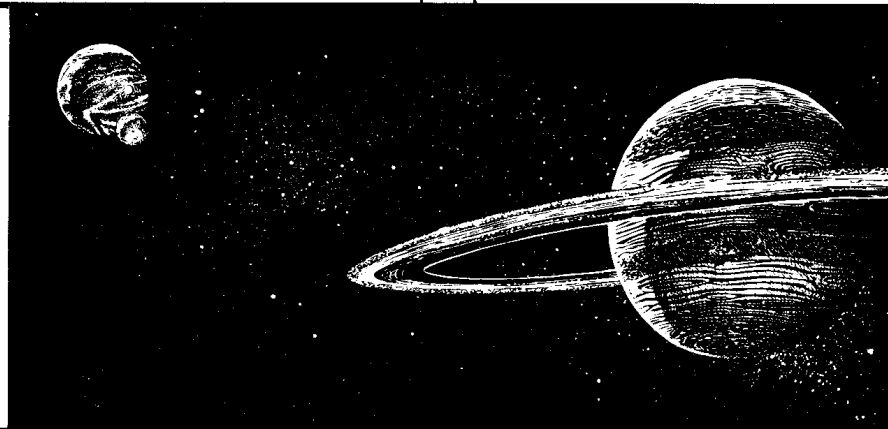

The Klingon agonizer is carried by most top-rank officers aboard ship, most notably the Captain, First Officer, Security Officer, Medical Officer and Marine Liason. The short cylindrical device has a contact grid on one end, a finger-grip groove on the bottom, and a thumbslide on top which controls the intensity.

The agonizer is usually applied to the left shoulder or upper chest, and can make contact through normal light clothing. Sliding the thumbslide forward produces anything from mild discomfort to crippling pain to unbearable agony at the user's desire.

When under the influence of the agonizer, a person must make a saving roll against the END attribute to take any type of action at all (other than screaming...). At higher settings, the roll is at a 50 point penalty for non-Klingon victims. (Klingon victims have a greater tolerance and get only a 40 point END penalty for the saving roll.)

The victim cannot lose consciousness under the influence of the agonizer, as the device artificially shuts off this defense mechanism of the brain via direct neurological stimulation.

Agonizers are not viable as combat weapons, as they require a solid touch near a major nerve center to work properly. (The left chest position is preferred, but any major nerve center will do. The pain produced is not localized in the contact area, except at lower power settings.) It is mostly used for discipline and torture.

There are rumors that certain cultures, perhaps even the Federation, have developed drugs which mask the agonizer effect. Such drugs would undoubtedly have side effects and would only be available to undercover agents and other critical personnel trained to use them only in emergency. Such drugs are known to exist within the Empire, but are highly illegal to produce, sell, use or possess.

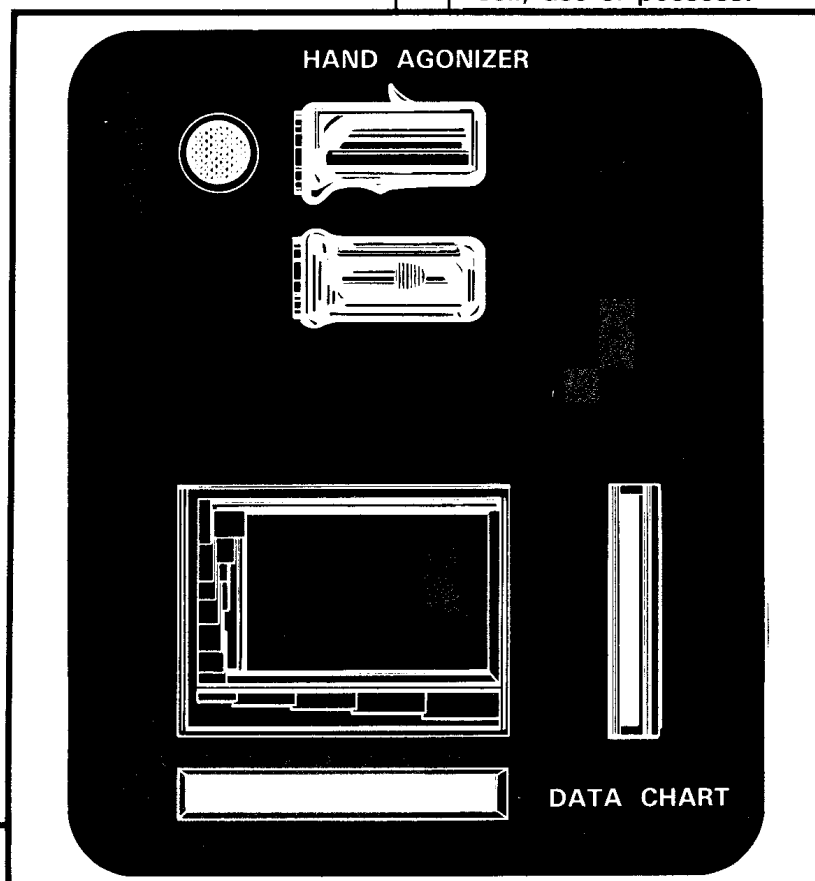

DISRUPTOR WEAPONS TABLE

	PARRY	DAMAGE	SHORT	MED.	LONG	EXT.	POWER	GRAZE DAMAGE	DRAIN
Mk I hand disruptor	—	75	1-4	5-10	11-20	21-35	20	25	2
Disruptor rifle	P	75	1-10	11-25	26-40	41-100	50		2
Mk II hand disruptor standard	—	75	1-4	5-10	11-25	26-45	20	25	2
high-power		destroyed	1-4	5-10	11-15	no ext. range		50	6
Mk III hand disruptor standard	—	75	1-5	6-15	16-35	36-50	25	25	2
high-power		destroyed	1-5	6-15	16-35	no ext. range		50	6
Mk III rifle standard	P	75	1-10	11-20	21-60	61-90	65	25	2
high-power		destroyed	1-10	11-20	21-60	no ext. range		50	8

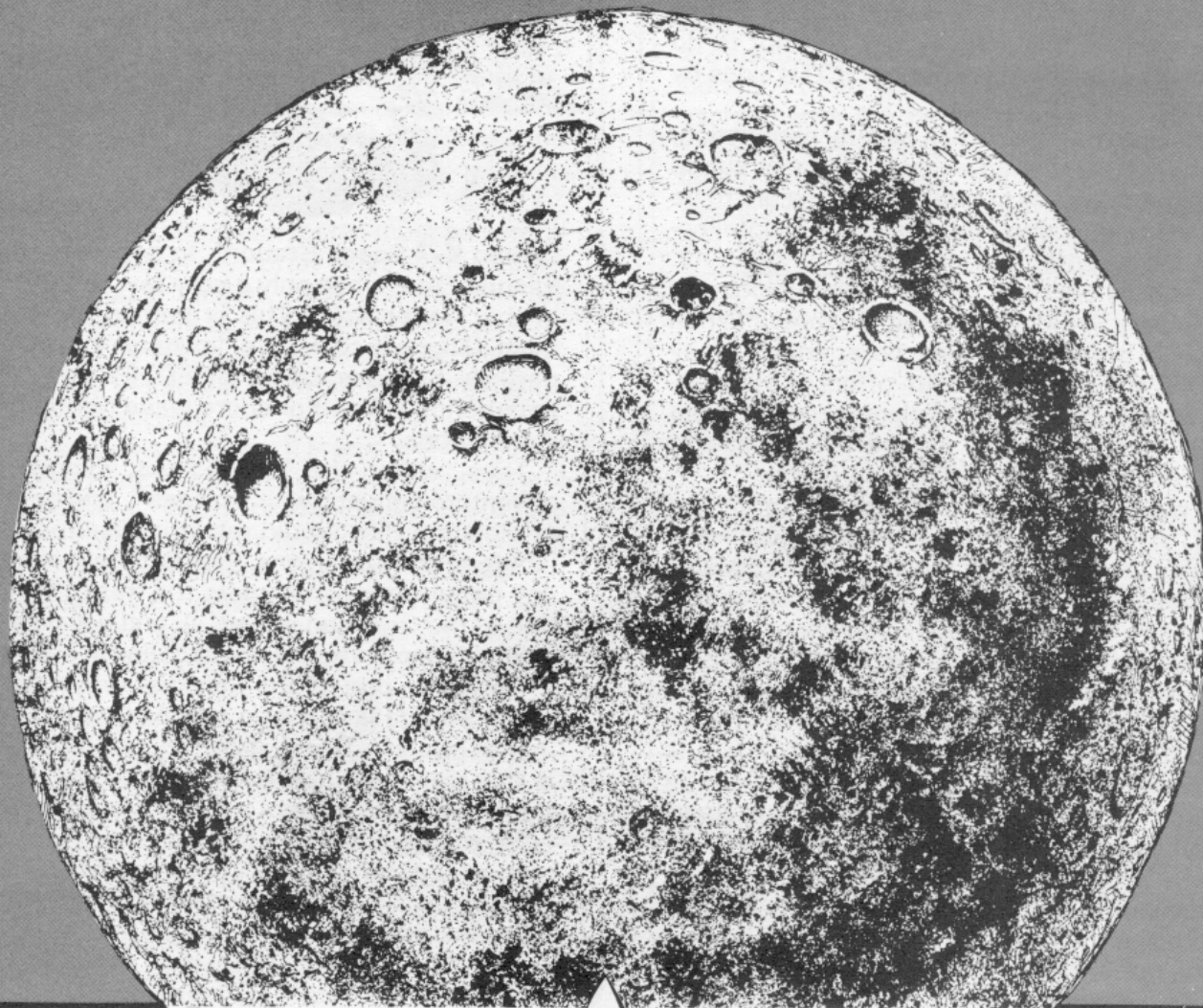

Planetside Adventures

Adventuring planetside for the Klingon player character is likely to be a bit different than for the Star Fleet player character, and gamemasters need to be clever (and aware of certain aspects of the interstellar political situation) to keep such adventures from becoming a turkey shoot. Klingon starship crews, particularly those of the Imperial Klingon Expeditionary Forces and the Exploration/Colonization Fleet, face many of the same situations as Star Fleet crews. They are likely to approach these situations, however, in a very different (and usually more — ahem — “direct”) manner. It is up to the gamemaster to see to it that the situation prevents the Klingons from simply shooting their way out of every encounter.

PLANETARY ADVENTURE AND THE PAX ORGANIA

The most important limiting factor for Klingon characters is the Organian Peace Treaty, forced upon both the Empire and the UFP by the incredible energy beings of the planet Organia. (See a discussion of this treaty later in this supplement.) In the Organian Treaty Area, no UFP or Klingon starship may fire upon the other. It is not only forbidden, it is IMPOSSIBLE to use starship weapons in this zone — any attempt to do so would bring instant disarmament of BOTH sides by the Organians.

Thus, problems must be settled here by negotiation, and through manipulation of events in a more subtle manner. Inhabited worlds in the Treaty Area are to be strictly left alone until such time as they are intellectually prepared to enter the interstellar community. (This is UFP policy anyway, but it is strictly enforced within the Treaty Area by Organian power...) When a civilization is prepared, it may be approached by BOTH the UFP and the Empire with offers of membership, trade agreements, etc. The planet's government or populace then has a free choice as to alliance, agreement, or total neutrality, if they prefer.

Planets without native civilizations (and the category of “native civilization” is broadly interpreted by the Organians to include sub-intelligent species capable of developing true sapience) are awarded by the Organians to the side capable of developing them and using their resources most efficiently. In the words of Commander Spock of the *U.S.S. Enterprise*, “The Klingons... ARE very efficient,” especially in mining and planetforming. The UFP, on the other hand, is more advanced in agriculture, and energy resource development. Thus, the divisions have been about half-and-half for the Empire and the UFP. The Organians review each case periodically to see that resources are used with continuing efficiency, for non-combat purposes.

Either side may maintain bases and non-military installations in the area (such as the UFP's privately-



owned K-7 Space Station). In practice, though, the Klingon Empire has only a very few refueling facilities in the Treaty Area. This is perhaps partly because most Klingon facilities are “military” by definition, and partially because crews of EITHER side may claim emergency aid and/or shore leave rights at any such installations.

Thus, within the Treaty Area, Klingon planetary adventurers must “walk on eggs”, and not risk a treaty violation that would result in disarmament at the hands of the Organians. The Empire will not tolerate any activity that endangers the treaty (out of simple fear of the Organian power...), and will punish severely any Klingon who steps out of line in such instances.

However, one of the quickest ways to get ahead in the Empire is to win a moral victory over the UFP in the Organian Treaty Area. This means commanders in this area must be especially devious, perhaps skirting the ragged edge of a treaty violation (as happened in the episode *The Trouble with Tribbles*) in pursuit of an advantage. Such activities are highly dangerous. To protect the treaty, those who fail such missions are severely punished by the Empire. But those who succeed find rich rewards and much prestige is the result of their efforts.

On the other side of the Orion colonial star systems — whose neutrality is respected by the Empire for reasons of their own — lies a smaller section where the UFP and the Federation touch borders — the last remaining section still referred to as the “Klingon Neutral Zone”, since most of the area once covered by that title is now part of the Oranian Treaty Area. Early on, much of this area — like the “Triangle” formed by the interface of UFP, Klingon and Romulan space — was considered mostly useless. Few inhabitable planetary systems and even fewer developable resources lie in this area. Thus, neither the Empire or the UFP was anxious to develop it and conflict was rare. Indeed, this area was not included in the Organian Treaty negotiations for that reason.

Later (after the events of the STAR TREK TV series), a number of planets in this area were found rich in dilithium and other valuable minerals — minerals which advances in mining technology had made practical to dig out. Eventually, it was patrolled heavily by Klingon warcraft — keeping just on their side of the Zone — and violators were pursued and destroyed as a matter of course. As yet, the Organians have not expressed a desire to extend the Treaty Zone, but too many incidents in the Neutral Zone might bring this option to their attention.

TYPES OF PLANETSIDE ADVENTURE

A **EXPLORATION** team would be the initial group to beam down to a newly-discovered planet. Such teams are always well armed and heavily guarded by Marines, but contain also scientific and command personnel. The job of a Exploration team is to determine if the planet is worth exploiting by the Empire, and finding out what obstacles stand in the way of such exploitation.

Within the Treaty Zone, such teams must be careful to avoid treaty violations — or at least being caught in such violations. If caught, they will be severely disciplined by the Empire to avoid a confrontation with the Organians. The only way to be caught, usually, is to have treaty violations reported by a Federation team or other observers.

If a native culture exists, such teams will report the fact, as well as reporting on exploitable resources and planetary dangers. Such teams rarely have the authority to violate treaty or take military action on their own, but an ambitious and bold commander might try it anyway for a particularly rich find. If successful, the Empire will not quibble about methods. Failure brings punishment, however, for endangering the Empire.

If a planet is found to be valuable in some way, an **EXPLOITATION** team may be dispatched, either from the same or another ship. Such teams may set up mining camps, observation posts, etc. If such is done in violation of treaty, such teams know they are on their own if caught by UFP observers. Space is vast, however, and many such efforts go undetected for months or years. Exploitation teams may suffer if the exploration teams failed to notice or report dangerous conditions.

If a native civilization is detected on a new world (either from space or by an exploration team), a **FIRST CONTACT** team may be dispatched. It is up to this team to negotiate with the native civilization for treaties and trade agreements, if such are allowed by the Treaty-determined regulations on contacting native cultures. First Contact teams will make alliance with the Empire as attractive as possible, hoping to win over the locals before the UFP representatives get a chance to state their case at all. First Contact teams must be strongly led by officers who are not too trigger-happy, or they may ruin their chances with a new native culture.

On uninhabited worlds with exploitable resources, a colonization effort may be mounted. Klingons often import servitor-race colonists to do the hard, dangerous work of proving a new colony. Many times, these “colonists” are political prisoners or others who are unwillingly transported from other Klingon-dominated worlds. Such colonies are first administered by a Klingon military governor and guarded/protected by Klingon Marines assigned to that governor. Once a colony is established, it is possible that a civilian puppet government will be established, with leaders of the dominant servitor race present. This situation can change in an eyeblink, with a new military governor and troops being sent if the colony does not adhere to Empire policy or fails to meet Empire production quotas.

Outside the Organian Treaty Area, inhabited worlds may be conquered by force. These raids of conquest are usually handled by the Imperial Klingon Expeditionary Forces backed by the Imperial Navy. Such assignments are highly prized (though dangerous), since leaders of such efforts are often rewarded by lands or exploitation rights on conquered worlds. Military governors are usually appointed from among the conquering leaders as well.

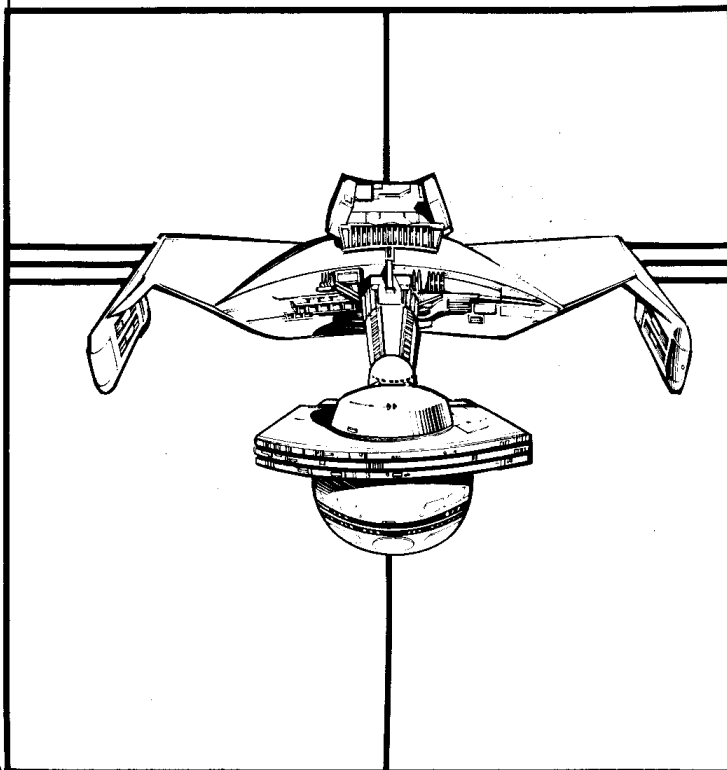

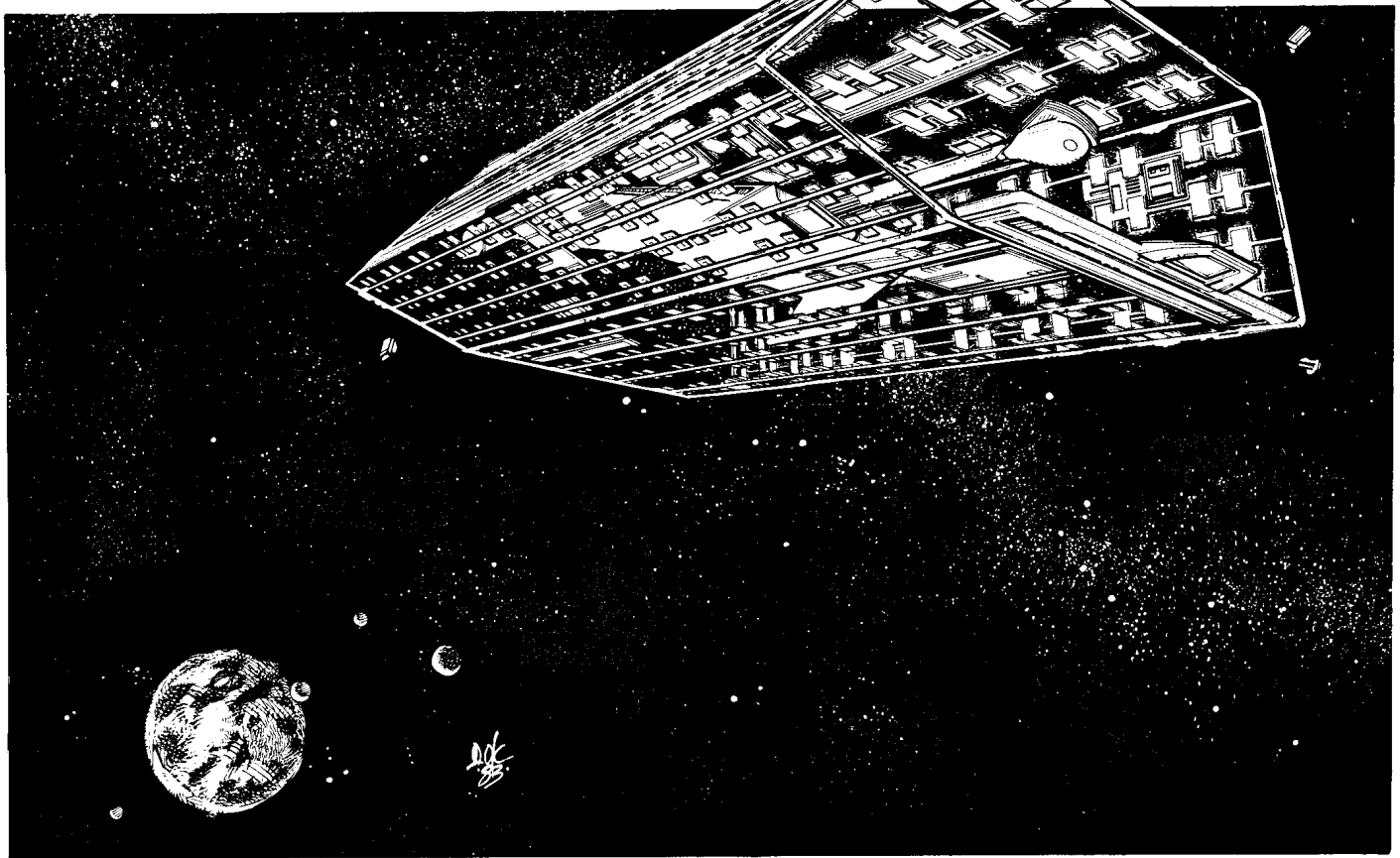

Conquered worlds are first subject to occupation by a strong force and are administrated by military leaders. This is eventually reworked into a military governorship and finally into a civilian government if the new acquisition behaves itself. Rebel activity will cause the Empire to increase the military presence, however.

The security-conscious Klingons have pushed the borders of their exploratory efforts beyond the area they can yet exploit. Thus, a line of frontier outposts is established at the fringes of explored space, where no colony efforts yet exist. Assignment to these posts is often a form of punishment for failure, or exile for those whose ambitious nature worries their superiors. Troublemakers are often sent on dangerous assignments into unknown territory, in the hopes that they will die gloriously and thus advance the Empire without threatening their superiors. Sometimes, such assignments can backfire if the "exile" beats the odds and returns with a rich prize for the Empire. (If he can manage to keep his superiors from grabbing the credit for it. Remember the well-known UFP joke: "How many Klingons does it take to install a light panel?" Two. One to install the panel and one to shoot him and take the credit.

History, Structure and Organization - The Klingon Empire

KLINZHAI - THE KLINGON HOMEWORLD

Complete scientific data on the Klingon Homeworld of Klinzhai is not available; in fact, Klinzhai's precise location is not known to the Federation. However, the following composite portrait may be deduced.

Klinzhai's star is brighter and hotter than Sol, perhaps an F7 or F8 spectral class. The orbital distance is longer, making the primary an intense pinpoint of light, capable of causing blindness if looked at even briefly.

However, Klinzhai is almost totally shrouded in clouds, and the sun is rarely visible directly. Nor are the stars; there is evidence that Klingons see a starry night sky less than one night in a hundred. As might be expected, "the naked stars" are objects of reverence, even awe, in the Klingon culture. There is a belief that any act done under the stars has special significance. This helps to explain the dominant role of the Navy: they spend their lives among the naked stars.

The cloud blanket creates a pronounced greenhouse effect. Mean temperature is some 15 degrees Celsius above Earth's, and global humidity is very high. The planet is reportedly quite lush, with extensive forests, jungles and swamps and no deserts. The oceans have been developed, but the polar caps are ignored (except, perhaps, as military reservations).

Klinzhai's day is somewhat longer than Earth's and the year is about 10% longer than the Federation Standard Year (Solar Year). The year is not divided into months (see next paragraph for possible explanation), though there are "hot" and "cold" seasons – possibly misleading terms as the annual variation in temperature is small. There is snow only in the highest latitudes.

The literature of Klinzhai does not mention a moon. This would mean that the planet's oceans are subject only to the weak solar tides. This suits the speculation that life evolved longer in the oceans, perhaps to the fringes of intelligence.

An Informal Guide to the Klingon Empire

Klinzhai is also perhaps the best-defended planet in the known galaxy. The natural distrust and paranoia of Klingons is at its peak in Klinzhai's defenses against attack. This is only natural, as Klinzhai itself is the hub of Klingon civilization and the seat of its government. Vulcan made contact with the Klingons long before the rest of the Federation, yet it has no official records of the location of Klinzhai. Despite this, there are Vulcans who have been there and returned. The circumstances of these visits are not discussed by Vulcan officials or individuals.

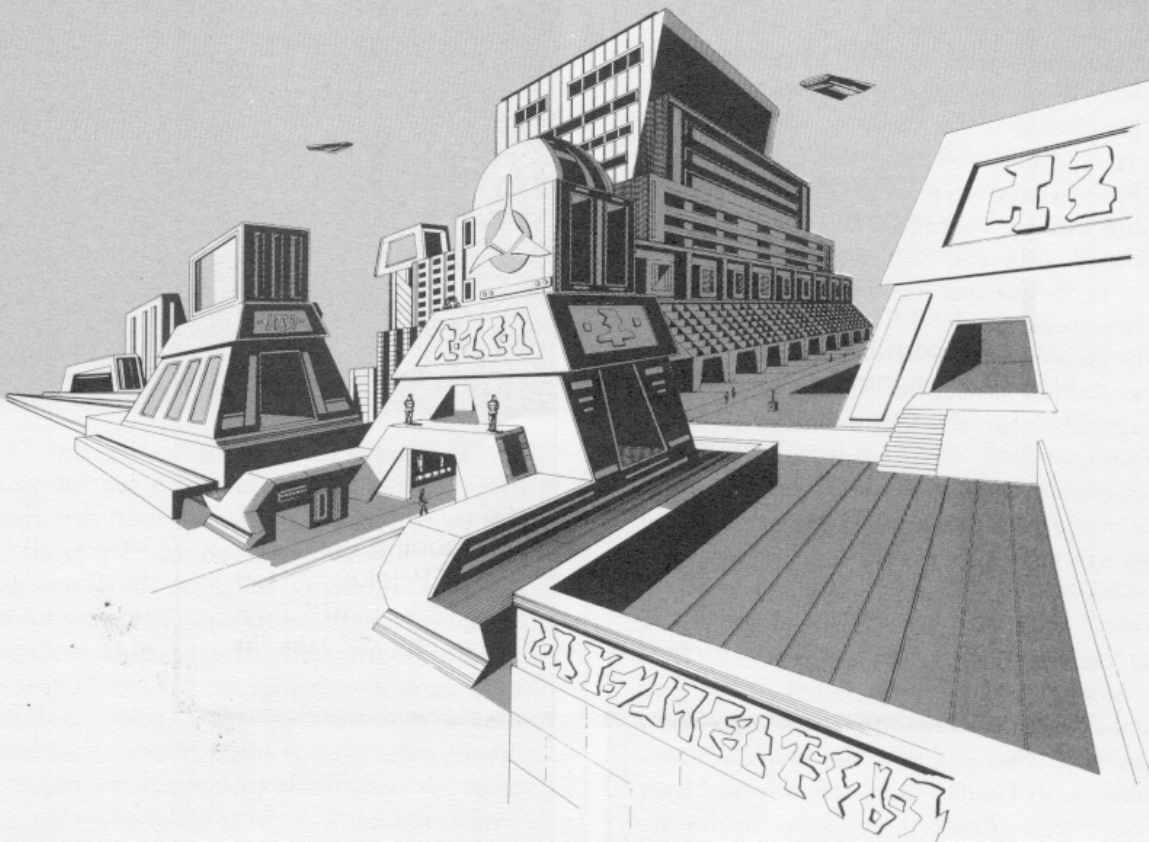

DANA KNUFSON

From fragmentary evidence, Klinzhai's original civilization seems to have been based on personal followings, with the size of a political unit determined by the number of individuals the unit's leader could control. These units tended to split and coalesce freely, usually with some bloodshed at the transition. The rate of coalition increased as the principle of "safety in numbers" became more apparent. Advances in communication and weapons technology respectively made larger, stronger units easier to assemble and more necessary. The family lines gathered strength because of their natural cohesive qualities.

Eventually — roughly eight hundred to a thousand years ago — major geopolitical states formed. Some of these seem to have been ocean-based on ship flotillas or floating (possibly even submerged) cities. One of the authors of this work (Tagore) hypothesizes that the rivalry between the present-day Klingon Naval and Marine force is rooted in long-ago conflicts between ocean-dwellers and land-dwellers. Each of these states called itself *Komerex* the word we translate as "Empire".

We do not know when the Klingons developed nuclear weapons. The usual assumption, that they came very late, is based on nothing but cultural arrogance; Federation technology is NOT always in advance of Klingon. Perhaps the multipolar *Komerexi* kept a balance of terror. Without question there were wars and nuclears may have been used. But Klinzhai is not devastated. Beyond this, Klingons and Klingon literature do not say.

There seems to be a connection between the development of starflight and the final coalition into the present system of a sole Emperor and advisory Council. The "Span Hypothesis" suggests that, with the immensity of space established, those Klingons who could take the long view (always a minority, but sometimes an influential one) realized that it was no longer necessary of worlds to fight self-destructive wars over the division; there was enough Universe for many Empires.

The present system is between three and four hundred years old. There have been at least thirty Emperors; the exact number is not known. Klingon Emperors are not automatically venerated (see the comments on Klingon "religion" elsewhere in its document), though all Klingons know of the most famous ones.

The historically greatest Emperor — possibly the first sole Emperor — was Kahless of the line Riskadh, known as Kahless the Unforgettable (in translation, more exactly, "Kahless-who-is-not-forgotten"). Kahless was killed in a huge fleet action against the Romulans. He had sworn to return with his ship or die with it, and in a symbolic gesture tied his hand to the arm of his command chair. Since then, "Kahless's Hand" (*kahlesste Kaase*) has been a common Klingon exclamation. Similarly immortal are "Keth's hundred years" and "Kahha's crown".

(Interestingly enough, Kahless is depicted in Klingon art as physically similar to the Human-fusion Klingon sub-race. It has always been thought that the Human-fusion Klingons — or fusions with Human-like races — came later in Klingon history. This belief may have to be re-examined.) (Especially in view of Kirk and Spock's encoun-

ter with an image of Kahless in *The Savage Curtain* . . . — Designer's Note)

An Informal Guide to the Klingon Empire

KLINGON CULTURE AND "RELIGION"

Elsewhere we have discussed the "naked stars" and their significance to the Klingons, it is important to understand that this is not a "simple primitive belief." The Klingon does not necessarily believe that the stars *literally* watch and record his actions. Did the ancient Greeks of Earth literally believe that Zeus appeared as a white bull to carry off Europa? But such legends exist, and survive, because they are in some way useful. In the case of the Naked Stars, the need seems to be for a higher, absolute justice that Klingon society does not provide. ("Justice belongs to the strong," is a common Klingon proverb.) A fragment of a Klingon ballad may make this clear:

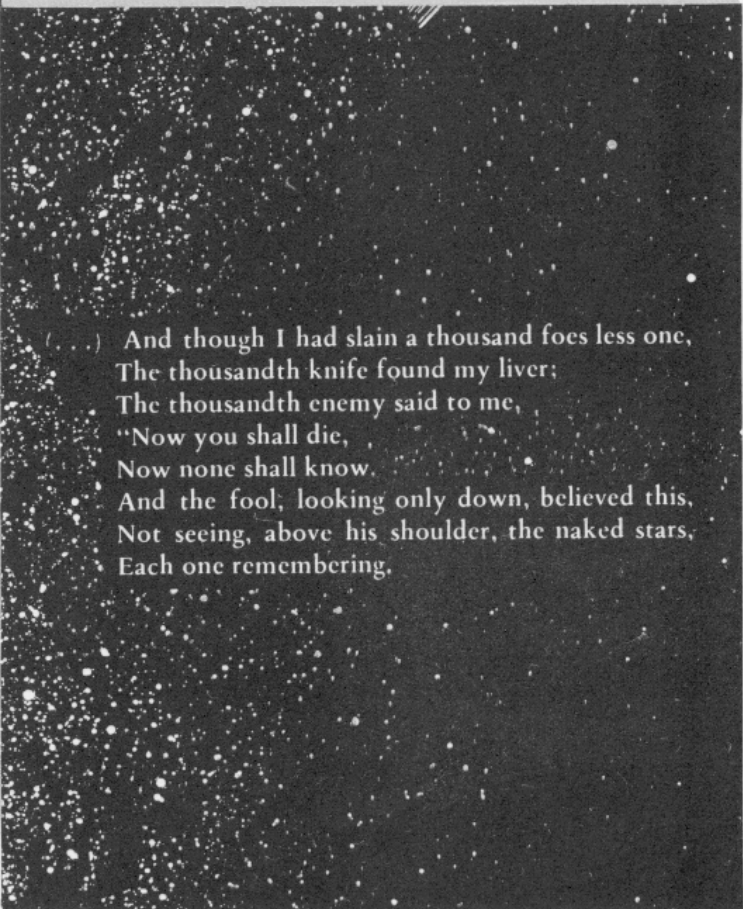

And though I had slain a thousand foes less one,
The thousandth knife found my liver;
The thousandth enemy said to me,
"Now you shall die,
Now none shall know.
And the fool, looking only down, believed this,
Not seeing, above his shoulder, the naked stars,
Each one remembering.

There is no Klingon idea of a god. The names of past Emperors or heroes, or of powerful animals such as the "stormwalker", are invoked, but this is no more religious than the human exclamation, "My God!" The Empire has encountered many religions, however, and is well aware of the strength religious faith can have. They do not wholly discount the idea of supernatural beings. In fact, they cannot — beings such as the Organians and the Metrons demonstrate powers that are god-like if not actually divine. But to put one's trust in another is not a Klingon trait. It is difficult to imagine a Klingon worshipping any entity that could be swayed by prayers.

An Informal History of the Klingon Empire

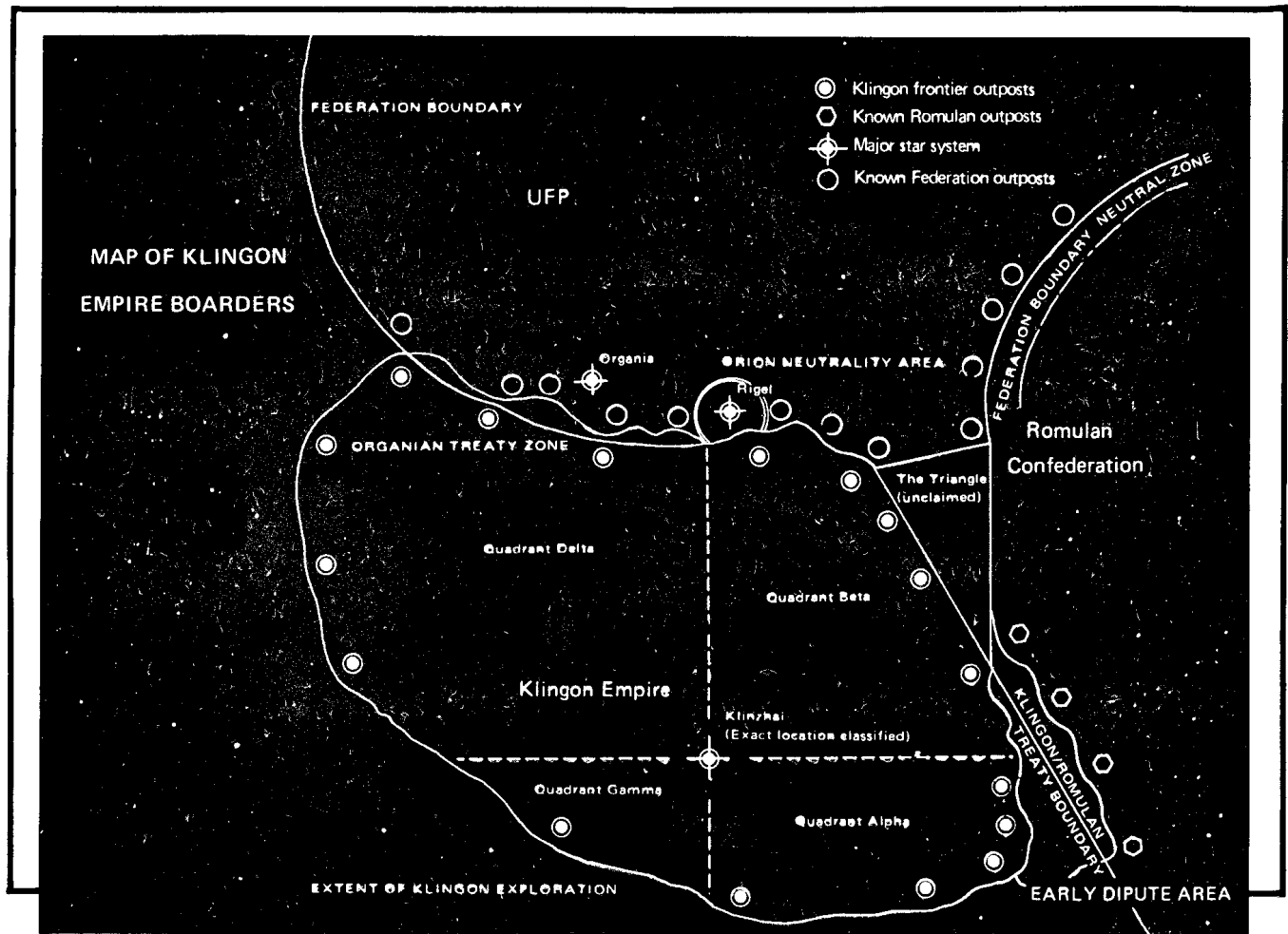

EXTENTS OF THE KLINGON EMPIRE

The expansion of the Klingon Empire centers roughly on the Klingon homeworld of Klinzhai. Unlike the UFP, the expansion of the Empire has not been as a slowly growing sphere, but in fits and starts as first one powerful line or consortium of lines grabbed and held valuable properties.

Early in their history of expansion, the Empire divided the galactic reaches into four quadrants (not to be confused with the "quadrants" used for UFP galactic navigation), named for the first four letters in the *klingonaase* alphabet, but called "alpha", "beta", "delta", and "gamma" by UFP historians. All then-existing lines were divided into four groups, and each group was awarded one quadrant to explore and exploit.

Klingon competitiveness doomed this idea quite early, however. Lines fought both inside and outside quadrant groups, and the quadrant/line arrangements crumbled. Now, any line may have holdings in any quadrant, but the quadrant divisions survive as geographical divisions of the Empire.

The lines holding Quadrant Alpha were quite successful in the early days of the Empire, and much exploration and exploitation took place here. This led the Empire into its first confrontation with another interstellar expansionist civilization — the Romulans. The Romulans are older foes of the Klingons than the UFP, with a hotly-contested dispute over a certain area rich in valuable star systems being finally settl-

ed (during the five-year mission of the *U.S.S. Enterprise* under Capt. Kirk) by a Romulan/Klingon treaty. The Romulan conflicts have left interests in this area tied up for some time, however, and it is not as well developed as the Empire would like.

Quadrant Beta exploration came later, as ships pushed out along the Romulan/Klingon border looking for undisputed systems of value. Much of this border (in an area known as "the Wedge" by the Romulans and "the Triangle" by the Klingons) is composed of useless systems incapable of supporting life and devoid of military, agricultural or mining value. Mostly, the Romulans and Klingons have both left this area undeveloped by unspoken agreement. Pushing along this border led the Klingons, eventually, to encounter the Federation and the "neutral" Orion colony worlds in the vicinity of Rigel. Recognizing early the UFP threat, the Klingons craftily supported the Orion neutrality with trade agreements and technological aid, knowing that direct action in this area would invite UFP use of force. Besides, the Klingons reasoned, the Orion pirates would be a thorn in the side of the UFP that might serve someday as an important distraction.

In later years (by the time portrayed in the film, *STAR TREK II — The Wrath of Khan*), the area between the useless "Triangle" and the Orion worlds would be found to contain worlds rich in valuable minerals. War threatened to break out here, leading the UFP and the Empire to eventually establish a stronger military presence here. This area remains as

the "sore spot" between the UFP and the Empire that may someday erupt.

Quadrant Gamma borders neither the Federation nor the Romulans, yet Klingon expansion in this area has remained somewhat limited. The reasons for this lack of expansion remain unknown to the Federation, but it is postulated that the Klingons may face other opposition on this side that is as yet not known to the UFP.

Quadrant Delta is the site of most of the Klingon Empire expansion in recent years. This section also borders the UFP, and an early Klingon Neutral Zone was established in this area. An almost-inevitable war here was nonetheless averted by the intervention of the Organians. The Organian Treaty Zone, backed by Organian mental power, still enforces the peace in this sector. The Klingons, however, have followed the UFP borders here and opened up new colony worlds and conquered holdings beyond UFP-held space.



SOCIOPOLITICAL STRUCTURE

The Emperor normally has a "shadow cabinet" of persons with his private trust; advisors, spies and secret agents — inevitably including secret bodyguards and an assassin or six.

The Imperial Council is made up of the highest military and governmental ranks. It may admit others, and even grant them a vote. Non-Klingons are not eligible, however.

The multiple arrows reflect that lower echelons are not answerable to the Council as a whole, but to factions (the Admirals, the Economic Planning Committee, etc.) or individuals within it. (See accompanying illustration . . .)

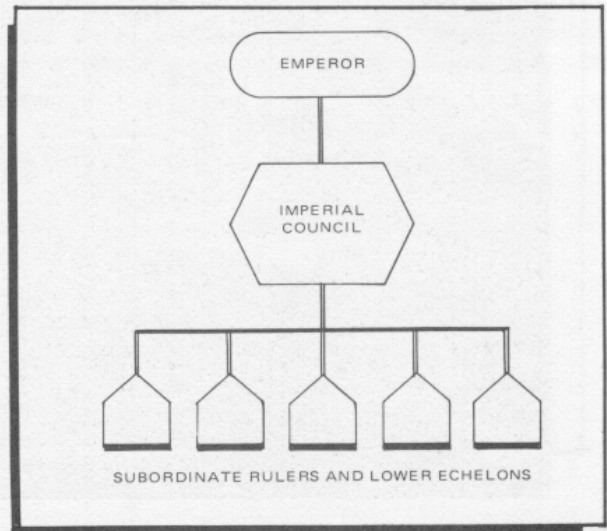

The Emperor is neither elected (exactly) nor chosen in trial by combat (exactly). It is not possible to become, let alone remain, Emperor without at least the consensus support of the Council. And sometimes single combat has been demanded, when the alternative would have been civil war.

Selection of an Emperor — in fact, of any leader — is based on the *komerex zha*, "the perpetual game." Not everyone plays . . . or do they? To some theorists, it is impossible NOT to play. Yet denying that one is a player at the game of society is a valid tactic of play, if you follow that.

Anyway, when the Throne becomes vacant, the Perpetual Game shifts into high gear. Personal power structures are tested to the limit, deals are made, debts foreclosed on. The "winner" becomes Emperor. The others adjust their positions, based on how well they played. Some may die, but that is not a necessary outcome.

The Game may be a necessary safety valve for the high power echelons of a society as internally stressed as the Klingons.

The average Imperial reign is 15 years, and ends with a death by natural causes. (Remember the shorter average life-span . . .) The longest was 70 years (Keth the Centenarian, whose longevity is not satisfactorily explained); the shortest was one hour (General Kagga, who was granted the accession while under sentence of death, in recognition of his exceptional skill outside the Game).

An Informal Guide to the Klingon Empire

Gamemasters must be especially careful not to allow player characters to accumulate too much political power too easily. There are many skilled players in the *komerex zha*, and anyone who looks too good is likely to attract the attention of other Klingons who view the character's consolidation of power as a threat to their own positions. It is conceivable that a player character might rise to a seat on the Council or even aspire to the Emperor's Throne, but not before spending literally YEARS of campaigning and careful building of a political and military organization. And for every one character that succeeds, a thousand will fail and more than a few will lose their lives for ambition.

IMPERIAL GROWTH STRUCTURE

It is not really possible for an empire to be an autarcy. All empires in the strict sense have made use of territorial governors, satraps, viceroys, counts palatine, puppet kings, General Jaruzelskis, Quislings, and so forth and so on.

The Klingons primarily use: Puppet Rulers
Imperial Governors
and Imperial Military Governors, in that order.

Nobody can afford to "oppress" (i.e. exert force on) a population to a greater extent than absolutely necessary. A world under an Imperial Military Governor and martial law would probably eventually pass to an Imperial Governor, and then to a local ruler (still answerable to the Empire, of course). But for a civilian governor to be supplanted by a Military Governor would imply the grossest incompetence on the ex-governor's part. And we know what happens to Klingons branded as incompetent.

(At the risk of being over-obvious, of course the civilian governor could call in the Marines to handle an insurrection. But he would do so with great care, especially since the Marine commander would be thinking about how he would have the Governor's office redecorated . . .)

Students of Klingon trivia will recall that, at first contact, the Klingons referred to the Federation as an "Empire"; i.e. they used the same word for both.

The word *komerex* means "the structure which grows". Its counterpart/antonym is *khesterex*. All societies are described by one of these two words. *Khesterex* cultures are by definition *kuve* (servitor races). There is no Klingon concept of an equilibrium culture, ZPG, etc. If a society is not growing, it MUST be dead.

Khex (or *Kh'ex*) is a slang term for "corpse," analogous to the human "stiff" or "flatliner," and is used in general for anything nonfunctional.

(NOTE: The authors are seeking funding for a sociolinguistic study of the enormous array of terms for things that do not work: the Rigellian "discount goods," the Orion "outgassed," the Tellarite "*quat*" (literally, "tastes lousy" or "inedible"), the Andorian "pink," etc. Only the Vulcans have no such word — apparently on Vulcan everything always works. We disallow the famed "illogical," since things may be illogical and still work. The book, when completed, will be entitled *A Bushel of Lemons*.)

An Informal Guide to the Klingon Empire

THE UNITED FEDERATION OF PLANETS: Relations with the UFP have been strained from the beginning. At first, the Klingon Empire regarded the Federation as a rival Empire to be fought when the proper time came. Later experience, and the Organian Peace Treaty, brought the Klingons to the realization that the non-expansionist Federation was not precisely *komerex* (a growing empire). Neither, however were they precisely *kuve* (servitor race) nor *khesterex* (a dead or declining culture). There are factions within the Empire that still favor treating the UFP as one or the other, the result being that the Empire takes a wait-and-see attitude for the most part.

The Organian Peace Treaty prevents the question from being decided by interstellar war. The first move by the Empire into UFP-protected space was the invasion of the neutral planet of Organia. The UFP was ready to go to war to protect the Organians, but the Organians had other ideas. Although they appeared to be humanoid in nature — simple farmers and peasants — the Organians were actually powerful energy beings who took humanoid form to put their interstellar humanoid visitors at ease.

The Organians are total pacifists, a concept that was frustrating for the UFP but almost intolerable for the Klingons. Unfortunately for parties on both sides willing to make war, the Organians had the power to back up their demands for peace. The powerful energy beings forced both sides to accept a peace pact calling for both sides to refrain from armed hostilities in a protected area along the UFP/Empire border near Organia. Any armed conflict in this area would lead the Organians to immediately disarm both sides.

Planets in the area are protected by Organian mental might, with inhabited worlds off limits until ready to choose how to enter the galactic society. Class "M" worlds are to be developed under the guidance of the side judged to be able to do so most efficiently. Forces of both sides must extend certain courtesies to their opposite numbers in the area, including shore leave rights, medical attention, etc. to be allowed at bases in the area. There seems to be no way to circumvent Organian intervention in any significant way, forcing the Empire to use more subtle methods of gaining a toehold in this area of space.

The UFP/Empire border skirts along the neutral systems of the Orions, near Rigel. Though the Orions are comparatively weak, and as neutrals are not entitled to UFP protection, the Empire respects their neutrality, and even extends the Orion systems favored status in trade and travel permits within the Empire. This practice is logical and typically Klingon in its craftiness — the "neutral" Orions practice piracy and are more of a thorn in the side of the UFP as independents than as a conquered or subverted part of the Empire. Indeed, the Orion planets provide a neutral haven for Klingon agents and a fertile breeding ground for turncoats and double agents. Part of the reason the UFP has not taken more concrete action against Orion piracy is their proximity to the Empire and the

danger that armed action by the Federation there would invite Klingon intervention and bring about full-scale interstellar war. Though no Klingon commander or leader would admit it, the Empire allows the Orion systems to continue their independence for the same reasons. Meanwhile, the Orions enjoy their unique positions and play the two sides against each other to the benefit of Orion interests whenever possible.

Beyond the Orion systems lies a small area of space where the Empire and UFP border that is not covered by the Organian agreements. During early years of Klingon/Federation relations (up through the time of the STAR TREK TV series), this area was not the scene of much conflict simply because there was nothing there worth exploiting. In later years (between the TV series and the time of *STAR TREK: The Motion Picture...*), there would be large deposits of valuable minerals discovered here. This is the only remaining section of the old "Klingon Neutral Zone", the rest having been absorbed by the Organian Treaty area. Any ship penetrating this zone into the other's territory is fair game for attack and destruction, and the Klingon Empire jealously guards the zone, patrolling with squadrons of its best ships.

Relations with the UFP have not necessarily worsened over the years, but they have shifted somewhat. Consolidation of more power by the Imperial Race Klingons, as they withdrew from contact with the outside, has led Klingons to have less contact with the UFP (by the time of *STAR TREK II: The Wrath of Khan...*). When contacts occur, they are rarely friendly in nature.

THE ROMULAN CONFEDERATION: Contact with the Romulans goes back much farther than Empire dealings with the UFP, though the UFP remained unaware of those dealings until much later. The Romulans are definitely *komerex*, in the Empire's eyes, and as such are most dangerous but more comprehensible and predictable in Klingon eyes.

Most of the conflict between the Romulans and the Klingon Empire has been over a disputed area of space directly between them. This area has many desirable planets, and neither side was willing to let the area go to the other without a battle. The resulting conflicts drained the resources of both sides. The Romulans, however, suffered from a technological deficiency in warp engine design and ship construction facilities, and this counterbalanced their greater command of space combat tactics and strategy.

Eventually, with both sides sick of the endless, fruitless battle, the Romulans attempted a long-delayed penetration into Federation space with a newly-developed cloaking device (*Balance of Terror*). When the attempt failed, the Romulans realized that they needed both a technology boost and an end to the drain on their resources caused by the Klingon conflict. The Klingons, too, were ready to call it quits, provided they came out of the deal ahead.

Thus the Klingon/Romulan Technological Exchange Treaty was completed. The Romulans gave up claim to most of the disputed area as a plum to bring the

Klingons to terms. Both sides provided the other with items of technological development that — in theory — would better BOTH sides' position vis-a-vis the UFP, their common rival.

The Romulans provided the Klingons with cloaking device designs, but these proved of little use to the Empire, as the Federation had already learned much about penetrating the cloak, and would soon get a copy of the device to study (*The Enterprise Incident*). Another bit of Romulan war technology, the plasma beam, did lead the Klingons to the refinement and construction of their own photon torpedo weapons, which make the new updated D-7 battlecruisers a potent threat.

The Klingons helped the Romulans end their ship design and construction gap by providing them with a number of older D-7 style ships equipped with Klingon weapons and engines. The Romulans have made extensive use of these ships, and have duplicated aspects of these ships in their own newer designs, including the adoption of Klingon disruptor weapons as primary ship armament. The hand disruptor (Mark I), plans for which were included in the agreement, has also come into widespread use in the Romulan military effort.

The agreements thus reached have not totally ended Klingon/Romulan rivalries, but they have helped both sides to be more at ease with their neighbor and allowed both to concentrate more of their military efforts on the Federation. There are still "incidents" however, mostly involving Klingon "privateers" who raid in Romulan space.

OTHER GROUPS: There is no evidence currently that the Klingons have encountered or made agreements with either the Gorn or the Tholians. It is highly unlikely that any such interchange would result in any sort of cooperation. The Gorn are too gruff and expansionistic, and the Tholians too totally alien to relate to the Klingons as anything but enemies. The Empire, however, has a vested interest in seeing that no other group, especially the Federation, makes any sort of lasting military alliance with these groups. Thus, the Empire is not above a little clandestine intervention in this regard.

There is some evidence that at least one other spacefaring race may lie beyond the Empire, unknown to the UFP. The nature of this race (if it indeed exists at all), and its relationship — if any — to the Empire, is unknown.

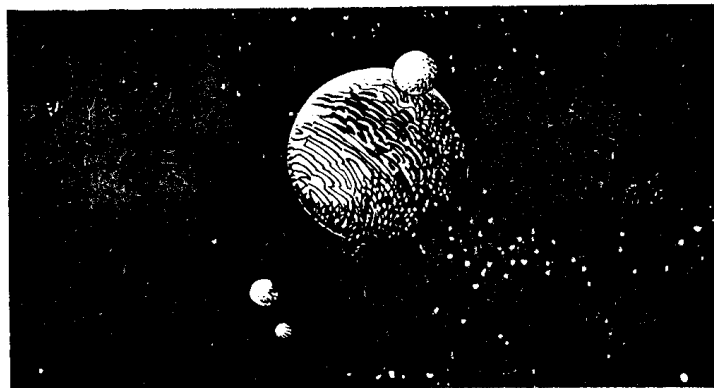

Imperial Naval and Marine Ranks

NAVAL TABLE OF RANKS

Recruit
Enlisted Second Class
Enlisted First Class
Petty Officer Second Class
Petty Officer First Class
Chief Petty Officer
Cadet
(Midshipman)
Ensign
Lieutenant Junior Grade
Lieutenant
Lieutenant Commander
Commander
Captain
Admiral

The rank system in the Klingon military is similar to the Federation's, and for most purposes direct translations will serve. A few exceptions:

"Squadron Leader" is a position, not a rank, indicating which of the three captains in a squadron is in overall command. It carries more significance on the frontiers, where squadrons are very independent (and are usually referred to by the Leader's name, e.g. Keth's Squadron). A Squadron Leader is still a captain, and might still be addressed as "Captain" without insult - say, by another Leader. Lower ranks would rarely take the chance.

"Admiral" is a generic title for all Naval Officers above Ship Captain rank. If there is a possibility of confusion, the officer may be referred to more specifically as "Admiral of the Fleet", "Training Cadre Admiral", etc.

A "Thought Admiral" is a Fleet Grand Strategist, without direct command of ships, but - at least in theory - above all other Naval Officers. It is not an organizationally defined position: there may be no Thought Admiral, and there may be as many as three. It must be understood that Klingons, while master tacticians, are not by nature strategists, and tend to mistrust those who take the long view - even other Klingons. Thought Admirals are often treated as somewhat useful but dangerously erratic.

An Informal Guide to the Klingon Empire

As can be seen, the rank of Cadet (and Midshipman, basically a passed Cadet) is listed on the table just below Ensign. A Cadet is an attendee of the Klingon equivalent of Starfleet Academy. Unlike the Starfleet Cadet, however, the Klingon cadet does carry the full responsibilities of an officer along with the respect and courtesy due.

MARINE TABLE OF RANKS

Recruit
Enlisted Second Class
Enlisted First Class
Lance Corporal
Sergeant
Sergeant-Major
Lieutenant Junior Grade
Lieutenant
Captain
Major
Lieutenant Colonel
Colonel
General

Again, the rank of General is generic as the Admiral is in the Navy. There are many, many Generals in the Klingon Marines, the differences being in the duties being performed.

A Marine "Force Leader" is in command of one ship's complement of Marines, including all ship's troops except those assigned to Ship Security, who are under the Security Chief's orders.

An Informal Guide to the Klingon Empire

OTHER RANKS AND TITLES

Ranks and titles extend beyond the Navy and Marines. The Klingon philosophy of a title for everyone extends into civilian life, as evidenced by the excerpts below:

While civilian titles are in use in the Federation - Doctor, Senator, President are all examples - the Empire is much more rank-conscious, and *everyone* has a title. Not to introduce a Klingon by title at anything like a formal occasion, and most informal ones, is a considerable insult.

Where a specific title such as "Procurements Manager" or "Traffic Coordinator", is not applicable, the generic "Administrator" may be used for a member of the bureaucracy.

In the sciences, "Specialist" is the lowest generic title. An "Accredited Specialist" has some technical credit worthy of note - a major publication, or the equivalent of a basic patent; some Klingons are more concerned than others over whether or not their accreditation is mentioned on all occasions.

The highest technical rank is "Thought Master". There is no direct Federation equivalent, but a Klingon Thought Master should be treated as a tenured full professor with multiple doctorates, an authority in his or her field.

An Informal Guide to the Klingon Empire

CHAIN OF COMMAND (Vessel)

- Captain
- Executive Officer
- Chief Helmsman
- Chief Weapons Officer
- Chief Navigator
- Chief Communications Officer
- Chief Engineer

On occasion, the captain of a vessel may be unable to command. The reasons are numerous: the captain may be planetside, ill or injured, etc. This table gives the chain of command, or sequence, to be followed under normal circumstances. If any listed personnel are also unavailable, simply skip to the next available officer. Once these possibilities are exhausted, the chain of command follows the ranks from senior officer present on down.

CHAIN OF COMMAND (Planetside)

- Base Commander
- Deputy Base Commander
- Chief of Staff
- Chief Communications Officer
- Chief Engineer

Same procedure as for vessels. Some bases may not have all positions listed. If this is the case, merely skip the position.



ROMULAN FUSION

All Klingon military forces wear the same basic uniform style, as illustrated here. Naval and Marine personnel wear the same uniform, the only difference being in color—the Naval uniform being black and tan; the Marine being in gray and tan. The vests worn are not just for ornamentation, being made of a heavy leather designed to help turn an assassin's knife blade.

The Klingons do not have a Federation equivalent of a dress uniform. They usually add a special sash which has "kill stripes"—a colored stripe for each vessel they have defeated in combat. These stripes are different colors according to the enemy defeated—Federation kills are in blue, Romulan in purple, and so on. The sashes themselves are different colors—tan for the Navy, dark brown for the Marines. Other colors are used for special services—silver for detached service, blue for the Klingon Diplomatic Corps (KDC), etc.

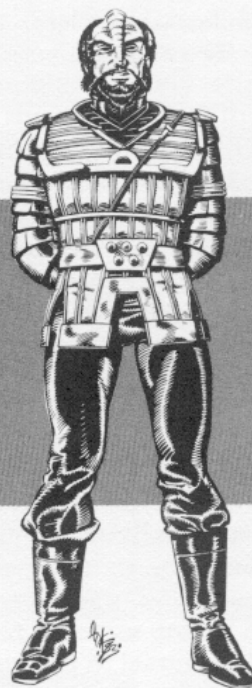

IMPERIAL RACE



HUMAN FUSION

INSIGNIA

The Klingon uniforms carry insignia denoting rank. Unlike Federation uniforms, however, one cannot always tell duty assignment. Some vessels do have official insignia for the vessel, usually because of some special distinction earned in combat. Many ship captains have unofficial ship insignia that the crew wears. The Klingons are very lenient about the use of these as they consider it promoting crew unity and morale.

Rank insignia is worn in the form of a brass circular badge on the left collar (see photo). The insignia on the right collar is where distinctive insignia (such as vessel assignment) is worn. This is also usually a circular brass device. This collar device is the only clue to rank. Most of the positions (remember all the admirals) do not have distinctive insignia as all Klingons assigned to a vessel or base are expected to know these superiors on sight.

DECORATIONS

There are numerous devices in the Klingon military symbolizing awards and decorations won in battle. The Klingons do not normally have "peacetime" awards, only awards for action. These awards can take many forms, the most popular being the battle sashes described earlier. Most other awards are rectangular or ovoid in shape, and can be given for many reasons. These are usually cloth and are sewn on the tunic (see photos).

NAVAL (MARINE) RANK INSIGNIA

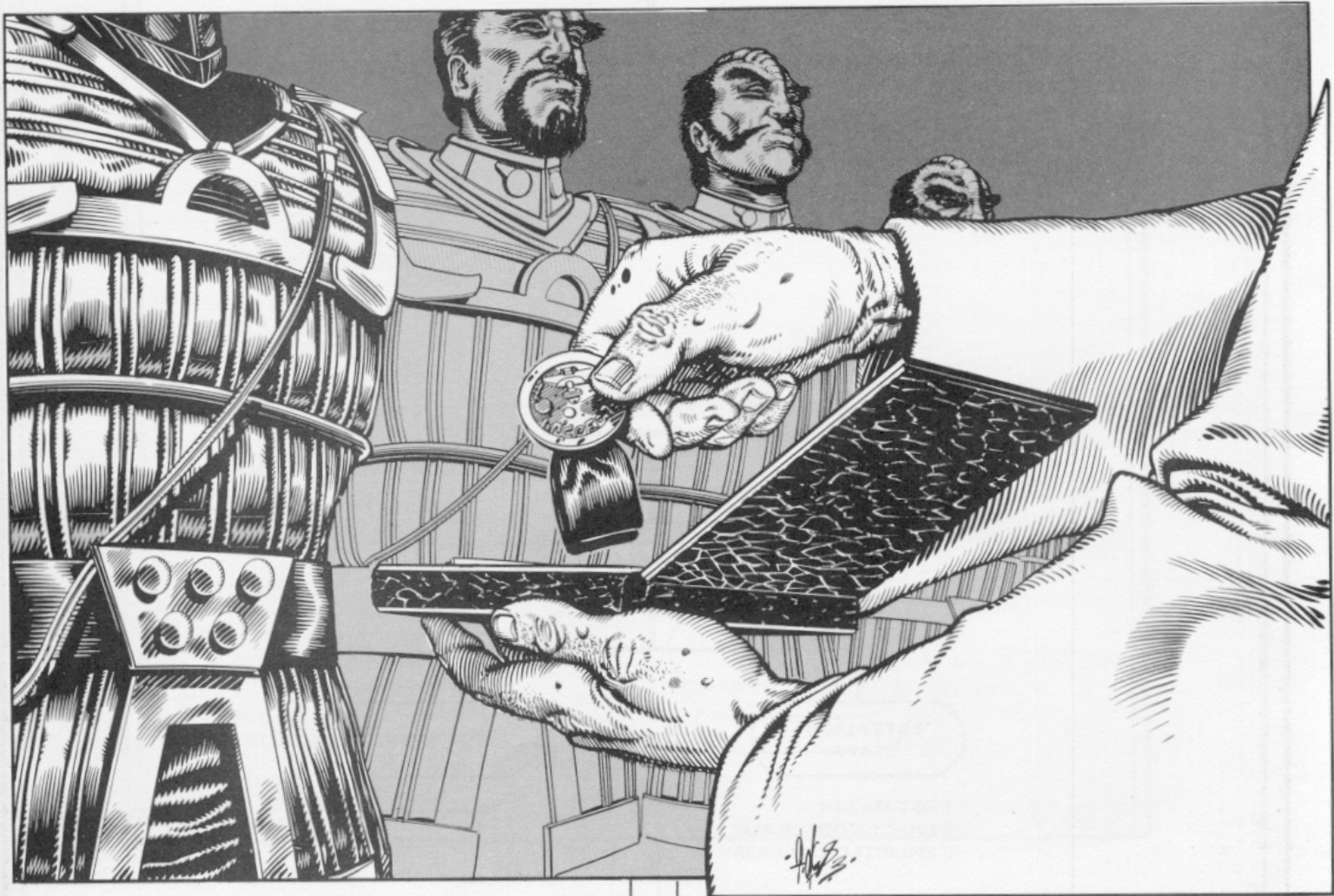
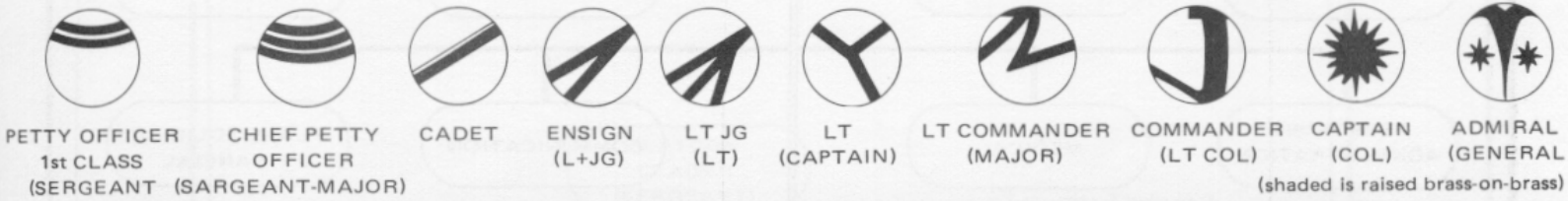
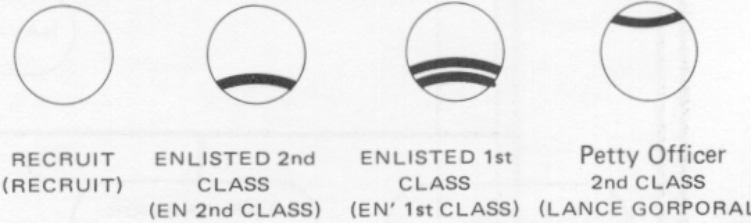

**ORGANIZATION CHART -
IMPERIAL NAVY**

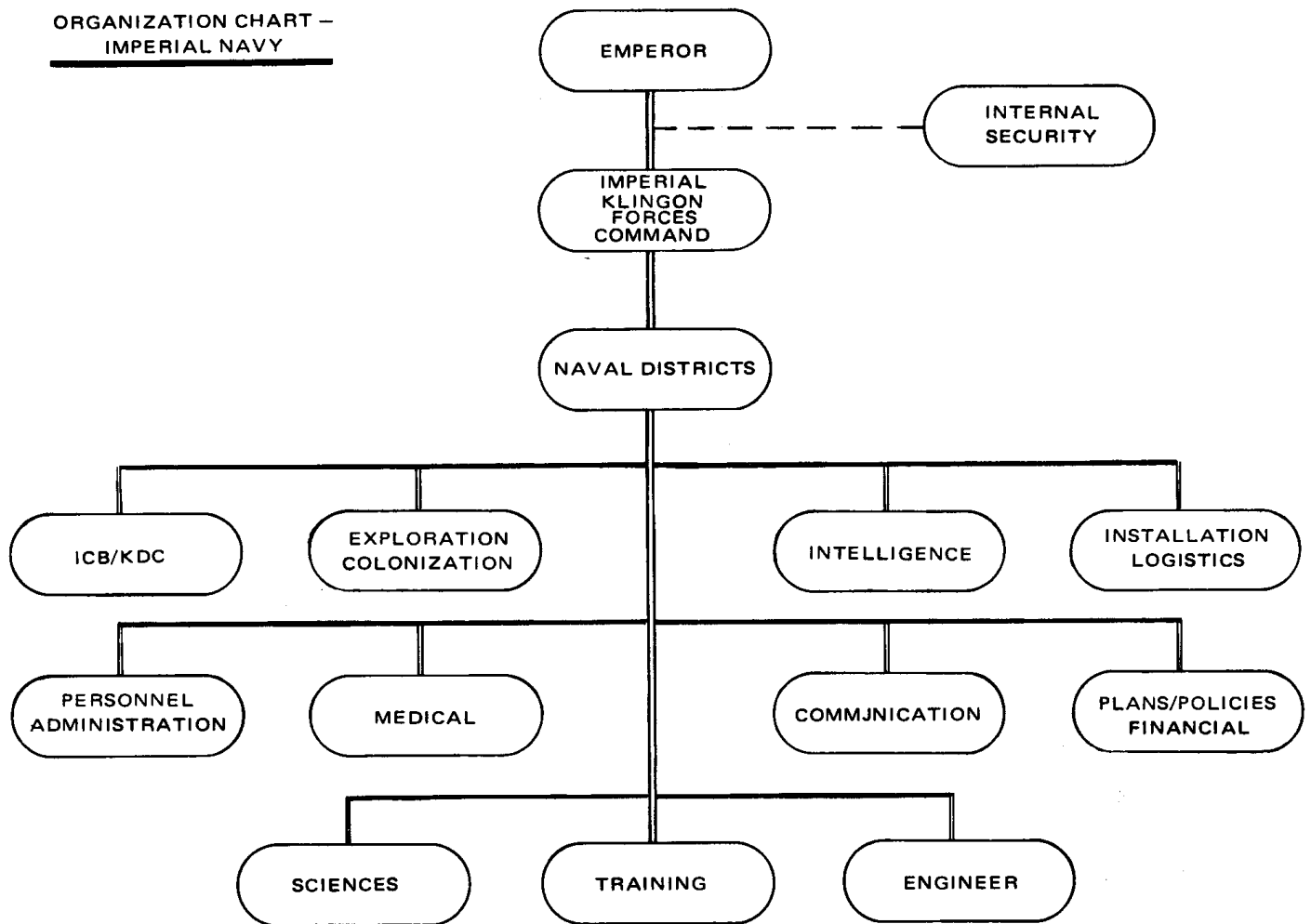

MARINE
BATTALION - 220 men

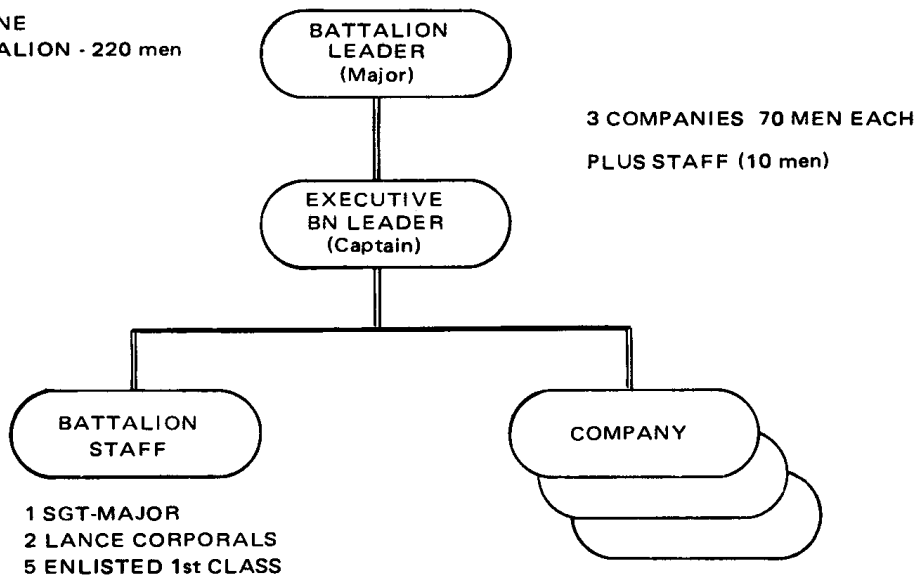

3 COMPANIES 70 MEN EACH
PLUS STAFF (10 men)

1 SGT-MAJOR
2 LANCE CORPORALS
5 ENLISTED 1st CLASS

SHIPBOARD MARINE ORGANIZATION CHARTS

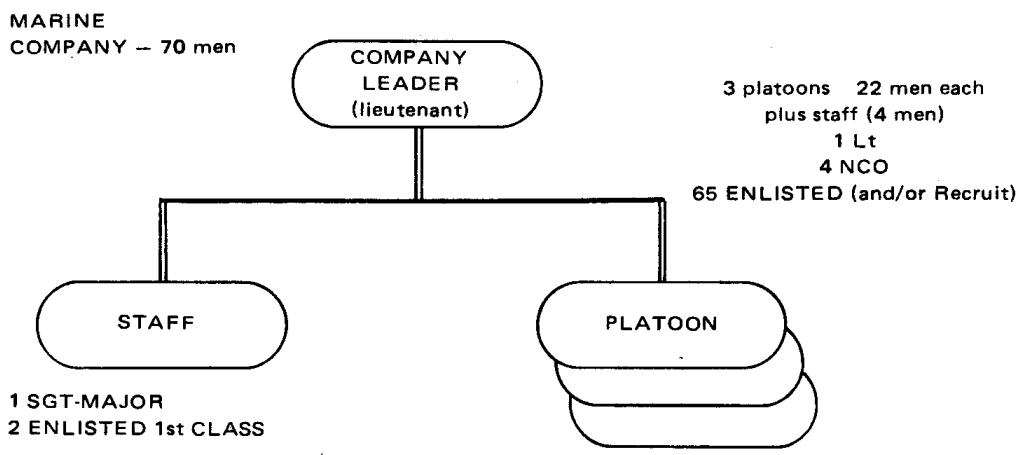
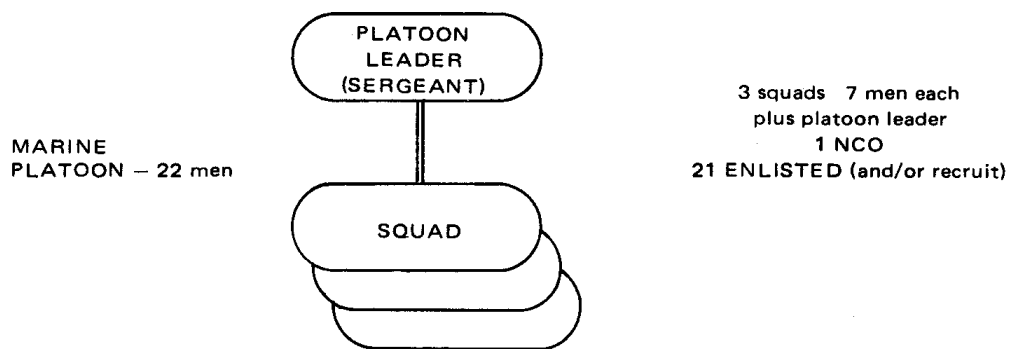
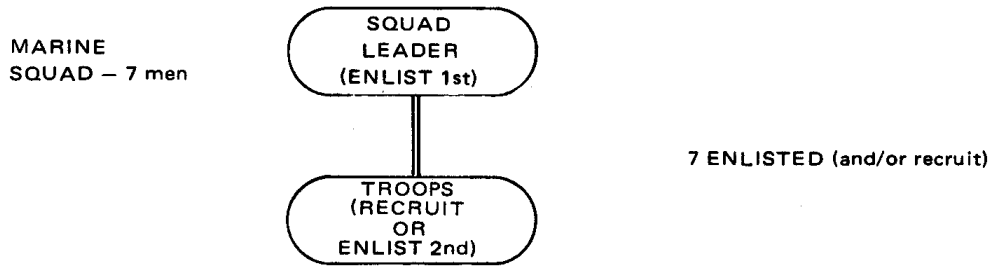

Organization of the Imperial Klingon Forces

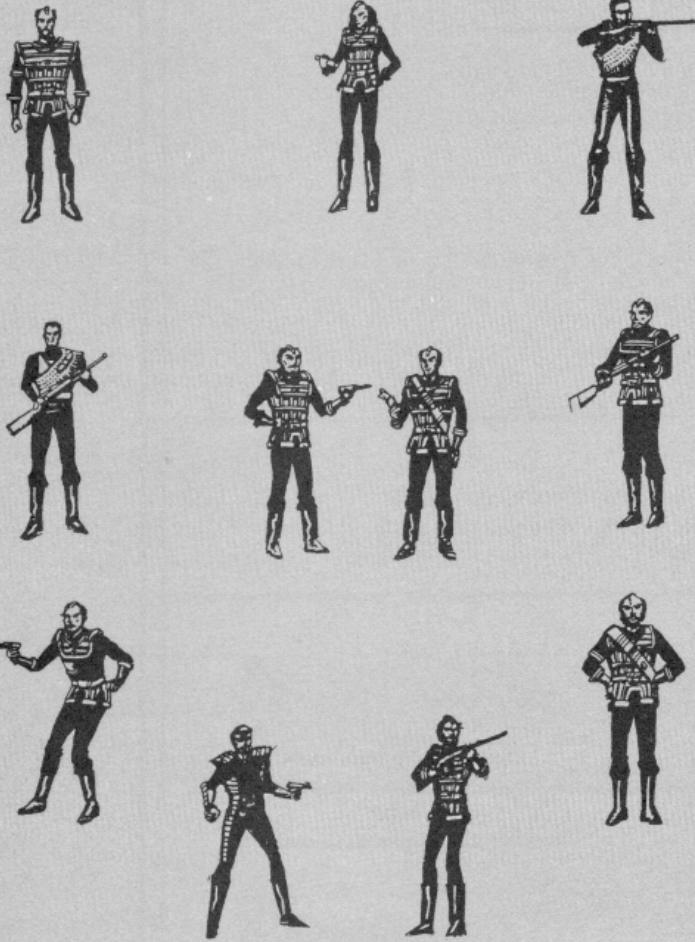

formance of duty, and generally being noticed in the right way. Fleets are assembled and disbanded according to mission. A mission can last from a few weeks to years. Klingon vessels generally operate in squadrons of three vessels and in fleets of nine vessels. Rarely will the Klingons assemble units in the third multiple, 27 vessels. This is done only with smaller vessels or in times of openly declared war. The reasons for this are many, the most prevalent being that rarely do the Klingons trust that many vessels under one Admiral's command. The Klingons would rather have several squadrons or two fleets under various commanders acting in some semblance of cohesion.

It will be noted on the organizational chart that the Internal Security unit is shown as being in the middle of the link between the Emperor and the IKF command. This is to show the role that Internal Security plays in the Empire. No one, not even the High Command, is safe from the eyes of the Empire. Internal Security has personnel everywhere, and not even members of the unit know who each other are. Members may be assigned side by side on a vessel and not know it. Internal Security's job is to insure the loyalty of everyone to the Empire. The means used are varied. The methods can range from spy cameras to 'interrogation'; from stealth to bribery; from lying to thievery. Just remember that Internal Security is everywhere, even when they're not. Internal Security also handles the normal military function of an Inspector General.

The IKF is broken down into 11 major departments. Each of these is composed of two or more smaller departments. These 11 departments are discussed below:

ICB/KDC:

The Imperial Contacts Branch is the precursor of the famous Klingon Diplomatic Corps. ICB's function is to coordinate efforts to bring worlds under Imperial hegemony by any means other than outright military conquest. Their main weapons are terror and torture - uh, excuse me, I didn't expect the Spanish Inquisition.

Their principal tactic is the exacerbation of an existing conflict among power groups on the planet in question. Sometimes this leads to what some people used to call a War of National Liberation, the outcome of which is rigged by Contacts Branch, either by supplying weapons or direct intervention. Often enough the intervention is not on the side of those the ICB was formerly "Helping".

ICB also stages pirate raids and "terrible accidents" as justification for Imperial operations.

Finally, they DO conduct real diplomatic operations; the Empire is always looking for willing allies, and is always cautious of colliding with a stronger or more ruthless culture than its own (both types exist).

An Informal History of the Klingon Empire

The Imperial Klingon forces' structure is streamlined compared to the Federation's organizational structure. This is due mainly to the Klingon way of life, not a more efficient organization. One major difference is apparent in that there are not four major divisions in the IKF structure, with smaller departments. There is no separate "military" structure—the IKF is ALL militarily oriented. The other major obvious difference is that the IKF is organized according to districts. Currently there are 17 of these, including frontier districts and the Klingon version of Civil Defense. These districts are similar to the Federation 4 divisions in that they draw on all the different departments for personnel needed for their particular assignment. These districts are drawn up and disbanded as needed, for the length of time they are needed. These districts are generally "geographical" in nature, the borders being redrawn almost constantly as systems are absorbed into the Empire or new foes are met. Originally, these districts were sub-areas within the four "quadrants" mentioned earlier, but they no longer respect "quadrant" boundaries.

These districts are assigned personnel, vessels, and equipment as needed. Naturally, the newer equipment and better personnel are assigned according to the Klingon philosophy. Transfers out of undesirable districts are attained by hard work, outstanding per-

EXPLORATION/COLONIZATION: Popularly known in the Federation (unofficially) as the Exploitation Branch of the Klingon military structure. Notice the functions are combined in the Klingon structure. This is due to the fact that the Klingons tend to colonize everything they can, even if with only a handful of personnel. This is so they can claim a body as belonging to the Empire according to "squatters rights" if for no other reason. The Klingon exploration teams are interested in what the Empire can get out of a discovery for the Empire's sake, not necessarily for the scientific value. Make no mistake though; there are many scientists in the Empire interested in scientific discoveries for discovery's sake.

Once the exploration teams have made a useful discovery, the colonization teams take over. To save time, often the exploration team IS the colonization team. This is why the two departments are combined in the Klingon Empire. Unlike the Federation colonization groups, the Klingons have no scruples over taking over a world already inhabited by sentient life, although usually the ICB intervenes in the occasion.

INTELLIGENCE: This department is responsible for gathering data concerning any forces hostile to the Empire. This office would gather data about military forces, their disposition and strength, and possible motives. Data about enemy civilian locations, their ways and settlements, economy, habits, psychology and sociology, etc. would be collected. In short, this department collects data concerning anything about possible hostile forces.

INSTALLATIONS/LOGISTICS: The quartermaster of the Empire. The I&L is responsible for the construction and maintenance of all bases, be they planetside or space station. This department is also responsible for resupply of all vessels and installations. All financial matters pertaining to installations, logistics, and procurement of new material is handled here.

PERSONNEL/ADMINISTRATION : Responsible for recruitment of new personnel and records of all personnel, active or retired. Controls the paperwork generated by the military structure, including forms, manuals, paperwork concerning transfers, promotions, etc.

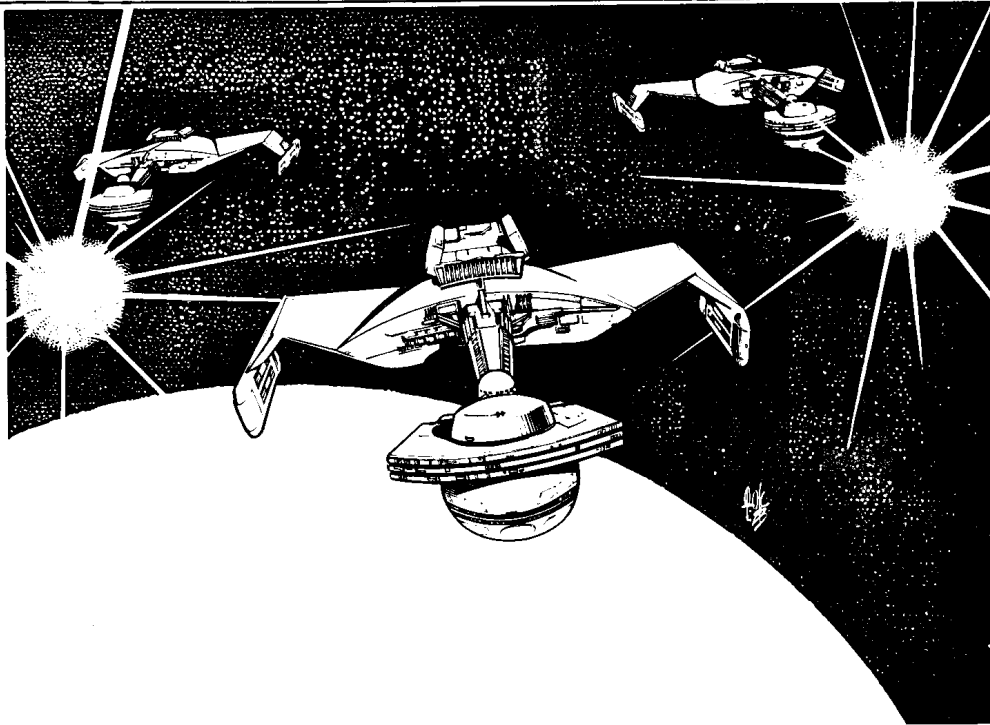

MEDICAL: Handles all studies and personnel related to the medical field, including genetic research.

COMMUNICATIONS: Handles communications of all types, whether it is sending a message within a ship or across the galaxy. Does R&D on communications equipment.

PLANS/POLICIES/FINANCIAL: All under one department in the IKF. Handles all plans, policies, and monetary matters in the military.

SCIENCES: Responsible for all research matters in the military not covered under any other branch. Unlike Federation policy, almost all research is carried out under military auspices.

TRAINING: Responsible for all training in the IKF. (See the rules section pertaining to the Academy for more information) as in the Federation, training never ends in the IKF, although less freedom of choice in studies is allowed.

ENGINEERING: Responsible for the maintenance, construction, and research of power units and related equipment for bases and vessels.

Shipboard Systems

In this section, details are provided on many of the systems and features found on Klingon warvessels. (By definition, the Klingons do not have civilian spacecraft. All starcraft are considered to be warships, and must be able to function — at least marginally — as such. An unarmed Klingon ship is a contradiction in terms. On vessels where mounted weaponry would be inconvenient or impossible — such as mobile dry docks — a small flight of armed ships is assigned as escort, nominally under the command of the larger ship's captain. This avoids that captain suffering the indignity of commanding an unarmed vessel.) The D-7 class Battlecruiser is used as the basis for descriptions in this section, but most entries apply to many other ships in the Fleet as well.

These descriptions are provided to give an adequate background for the capabilities of these systems in game terms. More detailed and specific information on systems are provided in the documentation accompanying STAR TREK ship deck plan packets from FASA. (Packets on the D-7 Battlecruiser and the U.S.S. Enterprise are available at this time, with more to come...)

Entries which basically duplicate information from the basic rulebook's Shipboard Systems section are not duplicated, but are noted here, along with additional pertinent information.

AGONIZER BOOTH: These shipboard interrogation devices are variations of the hand-held Klingon agonizer with more power and subtler controls. Use of such a device halves the permanent damage done in torture attempts (see skill description for Interrogation) while applying a 10 point bonus to the Interrogation skill roll. An agonizer booth can only be operated efficiently by a person with at least a 30 skill level in Interrogation and a 10 skill level in the appropriate racial Medicine skill. (Two people — one with Interrogation skill and one with Medicine skill — is allowable.)

COMPUTER, SHIP'S: Klingon vessels do not use one single controlling master computer for their ships, but rather apportion the job to a number of systems, each for a single task. These computers can communicate, but are not centrally controlled to the extent used on Federation vessels.

This is in keeping with the famous Klingon desire for security procedures above all. A decentralized computer is harder to knock out in battle and tougher for a saboteur to subvert. The disadvantage is that a "skeleton crew" needed to run a Klingon vessel is proportionally larger — about twice the size of a similar Federation crew — due to decentralization of computer tasks.

Klingon computers are not overlaid with artificial intelligence or "personalities". Klingons like machines to act like machines.

DEFLECTOR SHIELDS: Klingon deflectors work on the same principle and in much the same way as those used by the Federation. See basic ruleset for details.

DETENTION FACILITIES: Some newer Klingon vessels have adopted the Federation practice of using detention forcefields on brig cells. (See basic ruleset for details.) Most, however, use standard electronically-locked and insulated hullmetal doors, reasoning that a totally electronic system can be subverted more easily.

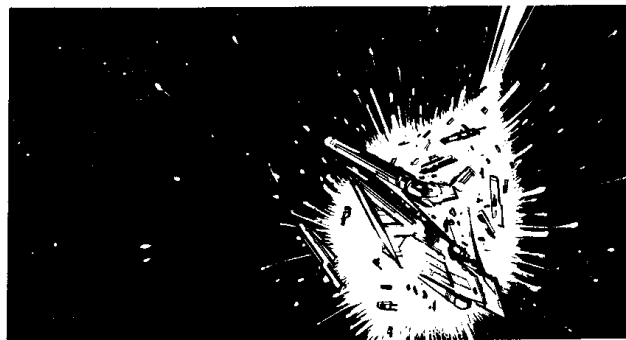

DISRUPTORS: Disruptors are the prime ship-to-ship weapon in use by the Klingons. (Romulan craft also use Klingon-design ship disruptors, as well as a number of Klingon-design ships.)

Shipboard disruptors act to suppress molecular bonding forces with a pulsed waveform. This causes oscillating stress and contraction of the target producing vibration and heating. This causes massive disruption of nervous tissue in living things, and this effect kills as many beings aboard target ships as the actual structural damage.

Disruptor weapons are not as subtle or versatile as phaser-type weapons, but the Klingons prefer them (though phaser technology is known to them) because disruptor banks are less of a power drain, easier to maintain, and less delicate than phasers. They also do not require the use of a dangerous gas as a coolant, whereas phaser banks do require such arrangements. It is also possible that Klingons psychologically prefer the more devastating, less humane and controlled weapon.

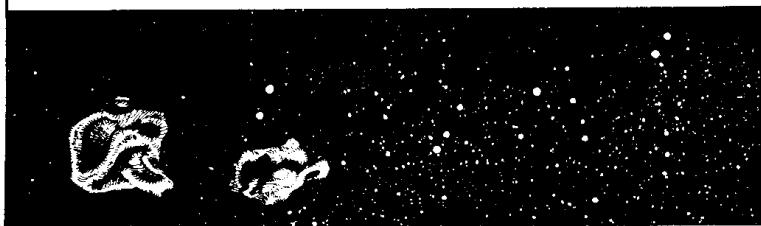

Disruptor fire from a ship can be directed against ground targets, but are not terribly accurate for that purpose. Klingon commanders, however, would mainly use such tactics as a move to induce terror in a population, or wipe out large areas. Thus, the lack of accuracy is not a particular handicap for their purposes.

DRONES: Many larger Klingon vessels carry robot drones mostly used as targets for ship combat practice and as probes. Drones are capable only of sublight speeds, and are not suitable for use as weapons in normal circumstances, though they can be fitted with warheads (doing 5 points of damage) if necessary. A ship carrying drones can launch one drone per ten seconds. Drones move at 1 hex/turn on the tactical display at sublight speeds. Drones launched at warp speeds are immediately destroyed.

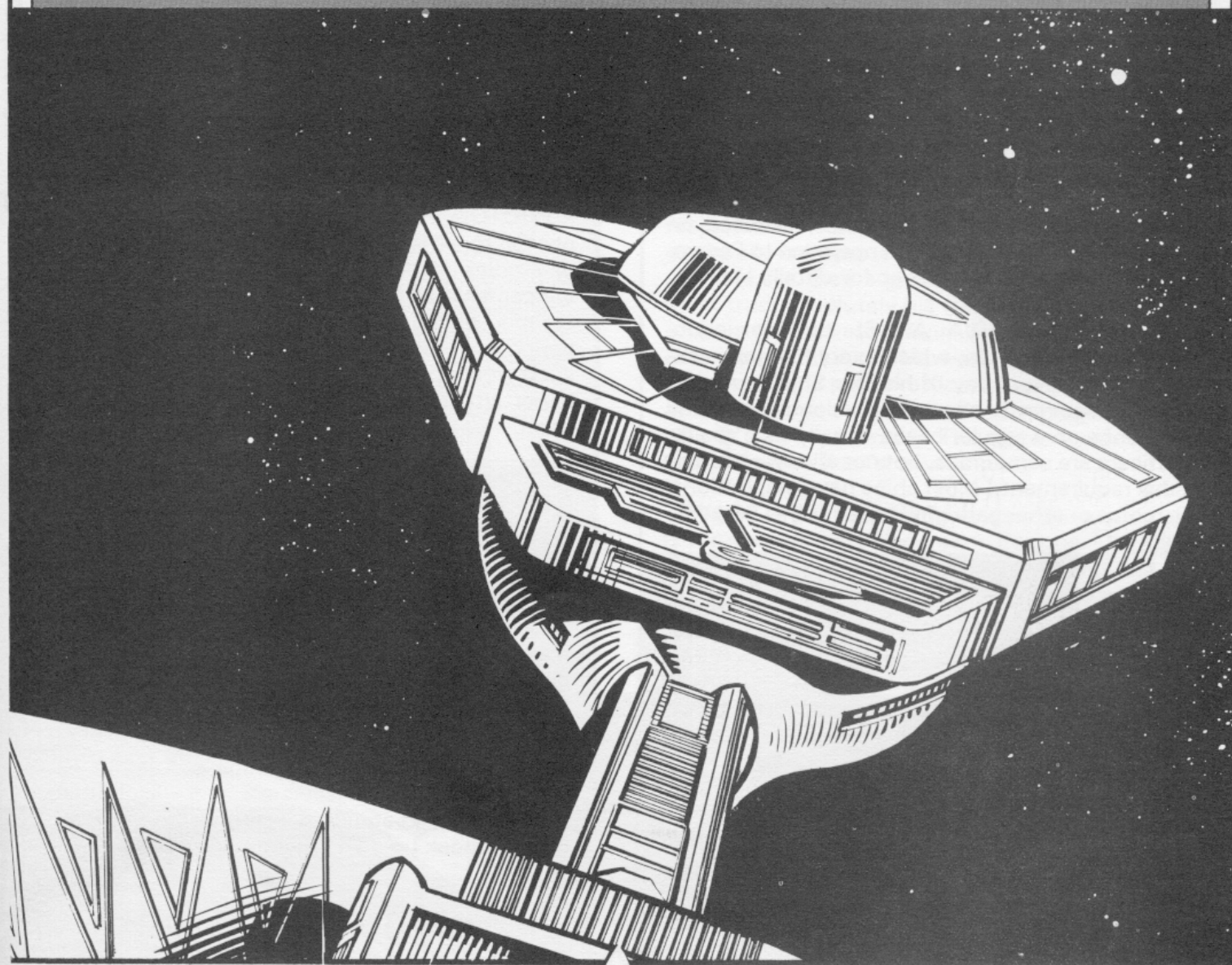

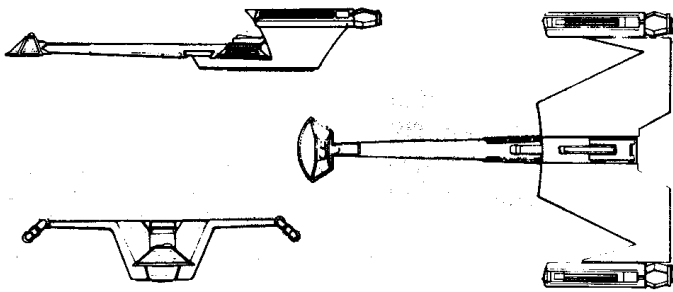

FOOD SYNTHESIZERS: Klingon food synthesizer technology is fully as good as UFP systems, but for the most part the Klingons don't bother to utilize it for all ship's personnel. Top echelon personnel have small, but versatile synthesizers operated by their most trusted personnel (and periodically personally inspected by top officers — after all, one can't take a chance of being poisoned...). Lower rank officers eat less well, with limited choices. Enlisted personnel and combat troops get what basically amounts to reprocessed food yeast.

GRAVITY, ARTIFICIAL: Klingon warships maintain excellent inertia-damping fields to protect the passengers and crew from acceleration and impact shock. They also have grav plates that keep the ship at a comfortable level of gravity (1 standard Klinzhai gravity) most of the time. Many Klingons, however, are quite adept at zero-G combat, and should artificial gravity fail, it would handicap a Federation ship more than an Empire vessel.

IMPULSE POWER: Impulse engines, as used on Klingon star vessels, are similar in operation to Federation systems. (See basic ruleset for details.)

INSPIRATIONAL MEDIA: A polite term for indoctrination and propaganda, which every Klingon is exposed to nearly every day of his life. Shipboard personnel are required to view inspirational films and presentations on a regular basis, usually as a group. (Top officers are sometimes, but not always, exempt from this requirement.) Most ships have inspirational media rooms or other gathering halls for this purpose.

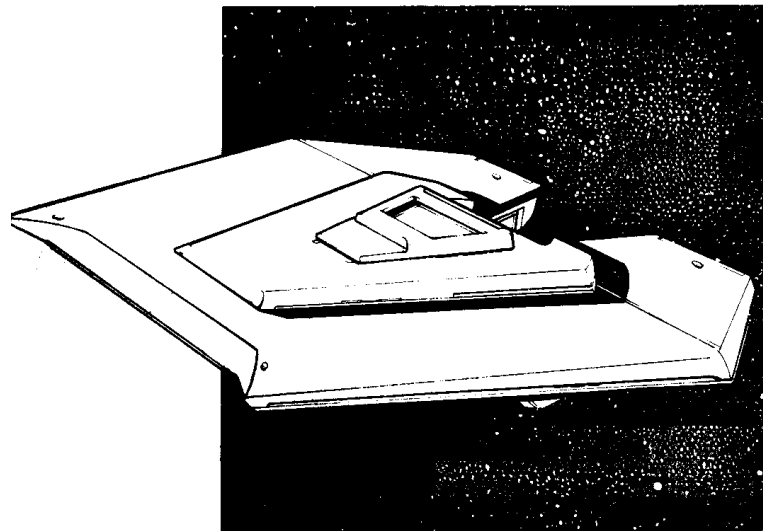

LOG, SHIP'S: Log entries are kept as per Federation practice, though most Klingon captains are not above doctoring log entries where necessary to save face. For this reason, it is not uncommon for ship captains, first officers, security chiefs and sometimes other top echelon personnel to keep secret logs as well. In addition, most ships have built-in log recorders maintained by Imperial Security. Some captains have found and doctored these recorders, but no one can ever be sure there isn't ANOTHER hidden recorder elsewhere. Such is life in the Empire.

MATERIAL FABRICATION: Klingon vessels make use of fabrication equipment similar to the Federation, but they do not rely on it extensively. Ships still maintain a ship's laundry in some cases, and such things as personal weapons are stockpiled. (See basic ruleset for details.)

NAMES, SHIP: In most cases, Klingon war vessels are known only by a designation code when they are first commissioned. A ship is named (usually by its commander) only after it has fired it's first shot at an armed enemy. There are exceptions to this practice. A veteran commander, assigned to a new vessel, would likely be allowed to name it immediately. It is also possible that a ship intended for some important mission would receive a name, especially if the ship was going on a particularly dangerous mission and was not expected to come back. Thus, being told to "name new steel" is a Klingon euphemism for being sent on a suicide mission.

PHOTON TORPEDOES: Klingon warships gained photon torpedo technology relatively late, as a result of studies of destroyed Star Fleet vessels and advancements as a result of obtaining Romulan plasma weapon plans. Only later Klingon vessels (after the period covered by the STAR TREK TV series) have such weapons, and even then they are found only on important ships-of-the-line such as uprated D-7 battlecruisers. (See basic ruleset for details.)

SENSORS: Sensor systems aboard Klingon vessels (except those mainly meant for scientific exploration — a rarity) are as sophisticated as Federation equivalents, but more specialized toward wartime uses. Thus, give a saving roll penalty of 10 points using Klingon ship sensors to scan for scientific data, while granting a 10 point bonus when looking for shield strength, damage to an enemy vessel, etc. (See basic ruleset for details.)

STANDARD ORBIT: Physics is physics. Standard orbits are the same for Federation or Klingon vessels. However, Klingon vessels are more likely that UFP ships to use non-standard, wildly varying orbits to confuse or sneak up on an enemy. (See basic ruleset for details.)

SUBSPACE RADIO: Similar to UFP technology, as subspace radio is a natural outgrowth of standard warp technology. (See basic ruleset for details.)

SURVEILLANCE FACILITIES: These exist aboard all but the smallest Klingon vessels in one form or another, providing a means by which all areas of the ship can be monitored. Usually, the manpower and computer time to monitor all areas at once cannot be spared, so only sensitive areas and trouble spots are monitored constantly, with random scans of other areas made periodically. When a being is trying to evade a search aboard a Klingon vessel, allow the Klingon crew a saving roll on the Crew Efficiency Rating (or the officer in charge a roll on Surveillance skill) with a successful roll causing intruders to be spotted if they enter a sensitive or important area. If the intruder keeps to non-sensitive areas, allow a 10 point penalty to the Klingon crewman's roll.

TRACTOR BEAM: This system is also in use in the Empire and in Klingon star vessels. (See basic ruleset for details.)

TRANSPORTER: Similar in range and capability to the standard Federation model, the Klingon transporter has certain differences.

The Klingon transporter, while it operates on the same scanning and reassembly principle as the Federation device, is silent in operation. This is because the Federation transporter uses a "super-carrier wave" in addition to the main signal. The two waves heterodyne at the assembly point, overdetermining the signal and producing parasitic noise effects. The super-carrier does not make transporter accidents impossible, as we all know too well, but it does make certain kinds of TA, such as signal dropout, almost impossible.

The Klingons consider this to be typically excessive caution by other races. They also use the transporter to place boarding parties, and for such use silence is a virtue.

It should be noted that the Empire developed and deployed transporters well before the Federation. The Klingons do not have the strict Federation restrictions on experimentation with living organisms.

An informal Guide to the Klingon Empire

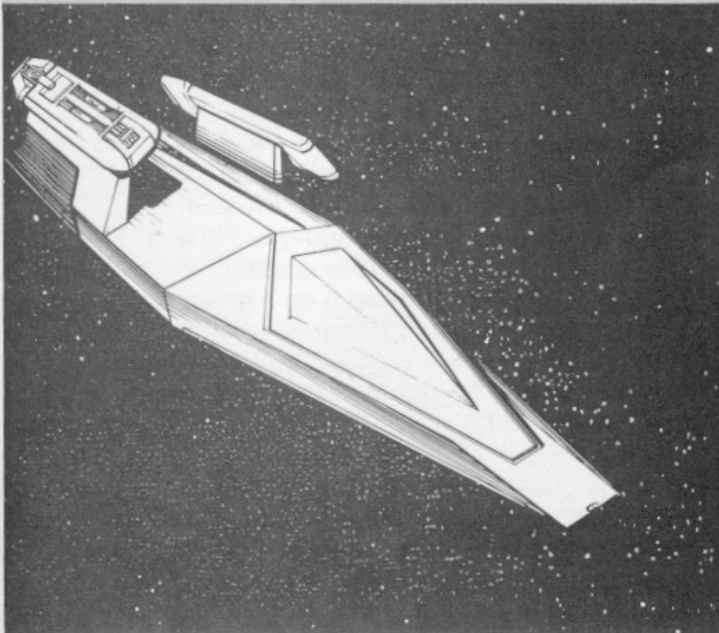

Federation experiments with silent, faster transporters had several disastrous failures. The idea of a silent Federation transporter was given up after a time. In fact, experimental transport failures led to stringent transporter shielding regulations in Star Fleet for a short time. It was tragically found that such shielding actually INCREASED the failure rate through interference with scanning waves. (See *STAR TREK: The Motion Picture...*) Finally, a system came into use that was safer than any previous design, and eliminated the need to immobilize and silence the transportee during scanning and reassembly. This system came into use in the Federation (by the time of *STAR TREK II: The Wrath of Khan*), but was still not silent. Hence, though the system is known to them, it has not been adopted by the Empire.

On ships carrying troops (such as the D-7 battlecruiser), huge mass transporters are often installed, allowing large numbers of troops to be dropped at once. Naturally, such systems draw enormous amounts of power. These are used only when orbital station is secured and no orbital enemy is left, since all shields and weapons systems are powerless while they are in operation. Even so, these transporters are failure prone. About 2% of the soldiers in a mass drop are lost to scanning or reassembly failure. These are considered to be acceptable odds to the Klingons.

For all Klingon transporter operations, apply an additional 5 point penalty to all saving rolls. (See basic ruleset for details.)

Top level Klingon officers (ship's Captains, or members of highly-placed lines) each have assigned a "transporteer" or transport officer. It is this officer's responsibility to check all methods of travel — especially transporter settings — to assure that they are safe for their superior officer. Since the officer must trust absolutely his transporteer, this person is often a member of a *kuve* (servitor) race, who can have no ambitions of his own. When this is true, the transporteer is not an officer himself, but carries full authority of his commander in matters relating to that officer's safety in travel. The transporteer often also acts as the officer's shuttle pilot.

WARP DRIVE: The Klingon warp drive is of basically the same type as Federation designs. The Klingons are perhaps less cautious with shielding and safety precautions, but there is no truth to the Star Fleet engineers' saying that Klingon ships can be readied for self-destruct easily because they are halfway there already. (See basic ruleset for details.)

Starship Combat

Included in this package are two new standard ship combat panels to use for Klingon vessels. On the Klingon vessels, weapons are handled by a Weapons Officer rather than by the Helmsman, as on Federation vessels. The play of the ship combat game is the same except that now a Weapons Officer handles the weaponry and the Helmsman panel is greatly simplified. The addition of the extra player adds realism to the role-playing aspects of the ship combat system. However, as in the system presented in ST:RPG it may be played with fewer players than suggested, with players handling more than one panel. There are no other changes to the play of the ship combat system.

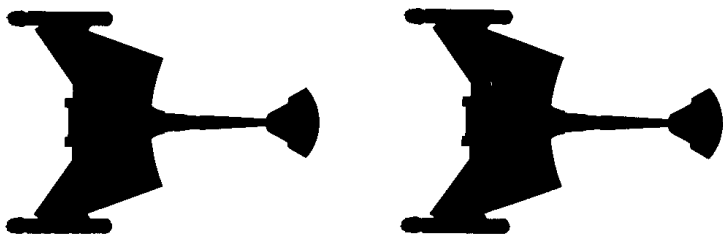

SHIP COMBAT PANELS

Included as inserts in the adventure book with this set are the following items:

FULL PLAYERS' COMBAT PANELS: These are included for the two most widely used variants of the D-7 Battlecruiser. The D-7A variant is in use during the TV series run of STAR TREK, and is the ship represented by the gamemaster panel for the D-7 in the basic ruleset for STAR TREK: The Role-Playing Game. The D-7M is the later version of the D-7 with photon torpedoes fore and aft (and heavier disruptors) shown in the beginning of STAR TREK: The Motion Picture and STAR TREK II: The Wrath of Khan, and it is used during the time period covered by those productions.

GENERIC PLAYER COMBAT PANELS: These panels supplement the ones provided in the FASA Ship Construction Manual for STAR TREK: The Role-Playing Game, and allow the preparation of full player combat panels for weapons officer and helm positions on ANY Klingon vessel. These generic panels are used just like the other panels in the Ship Construction Manual and replace that book's generic helm panel for use on Klingon vessels large enough to have a separate weapons officer's position.

GAMEMASTER COMBAT PANELS: These are provided for the Constitution class ships (like the Enterprise in the TV series), and for the Enterprise and Reliant class ships (from STAR TREK II: The Wrath of Khan). With these panels, the gamemaster may easily operate these Federation vessels which are often encountered by player-character Klingon crews as enemy ships. Gamemaster panels for other common Federation vessels are already provided in the basic set for STAR TREK: The Role-Playing Game.

SHIP CLASSIFICATIONS

All Klingon vessels are assigned a alphanumeric code for identification purposes. The alphabetic character describes the classification of the vessel according to the table below. The numeric character is the unique number designation assigned within the alphabetic class. Each vessel then has a unique code. Generally, the lower the numeric character within an alphabetic code, the older the vessel (though there are exceptions).

W Warp Shuttles

L Frigates
Battleships

D Destroyers
Light Cruisers
Heavy Cruisers

K Gunboats
Escorts
Patrol Craft

S Service Vessels

T Troop Carriers

G Miscellaneous (Not covered under any other class)



BATTLE LANGUAGE

Along with standard *klingonaase*, all Klingon youth learn a short-talk version called "battle language". Battle language is composed of shortened command forms, and is used, with great efficiency, in situations where quick, precise information or commands must be given. Battle language has the same roots as standard *klingonaase*, but is so compressed and altered as to be incomprehensible to the average non-native speaker of the Klingon language. Thus, all saving rolls to understand Klingonese speech made by a non-Klingon who has learned it as a second language are made at $\frac{1}{4}$ the usual Klingonese language skill level (round down). It is possible to learn battle language as a separate language skill, but its level may never be higher than $\frac{1}{2}$ the character's skill level in standard *klingonaase*.

Only quick commands and information can be given in battle language — it is not suited for long, detailed discussions. Also, translation devices that work for standard *klingonaase* speech translate battle language at no penalty.

Klingon vessels are not generally given "hull numbers" as such, in that the identification numbers are not painted boldly on the outer surface of the vessel as the Federation does. Each vessel does have a registration number, but these are not broken down into classes as the Federation does hull numbers. Registration numbers are assigned as the vessels are commissioned, in sequence. Therefore, the lower the registry number, the older the vessel.

Klingon vessels also are not given class names as the Federation does. In the Empire, a vessel has to earn its name. Vessels are sometimes given names that apply to their captain, such as Two Fingers. They may be named by their crew or Captain after glorious action with some appropriate name such as Death Dealer or Lightning Blow. They may be given a fearsome name after some action such as Night of Death. Occasionally these names may be painted on the hull as a visual warning to any nearby.

The *komerex stela* (Imperial trefoil) is usually painted on the hull of all Klingon vessels. It consists of a yellow circle, upon which is blazoned a long red sword-like point and two shorter fang-like projections — one green and one black — both curved in the counter-clockwise direction. The three points extend radially from the center of the circle and beyond its edge, at 120 degree angles to one another like an equilateral triangle. This is the symbol of loyalty to the Empire. It may or may not appear on privateer ships — supposedly operating without official Imperial sanction. It, of course, would NOT appear on Klingon-design vessels run by the Romulans.

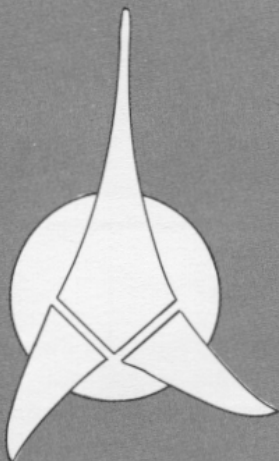

As mentioned before (in this section's counterpart in the basic ruleset), Klingon starship captains are not berserk killers, interested in destruction of any ship they encounter. Klingons fight when there is reason to do so, and if Klingon captains appear to be somewhat trigger-happy, it is because the only way they can advance in rank and status is to win victories.

Klingon captains have reasons and motives for their actions, and must be played intelligently. They also have obligations to superior authority that must be considered when they enter battle.

The Klingon philosophy involving combat encounters is, however, much different than that of the Federation. Klingons are very conscious of personal power and prestige, and one way to obtain such is to win substantial victories in space against the Empire's enemies.

The key words in the above paragraph are "substantial victories" — that is, victories with meaning that will impress (and perhaps overshadow) one's superiors. There is little glory in destroying an unarmed vessel, for instance, unless the vessel is a target of strategic importance in some larger sense — such as a critical fuel shipment or courier ship. In fact, attacking without reason or orders might often lead to disciplinary measures against the ship and captain involved, if the incident threatened treaties or agreements that the Empire was not yet ready to break.

Klingon Imperial policy does provide for a strong defense of Klingon space. A ship of any power that clearly violates that space without Imperial authority behind it is fair game for boarding or destruction. If the offending ship is of any size at all, boarding and capture would be preferred, especially if the vessel belongs to the military of any of the Empire's enemies, such as the UFP or the Romulan Confederation. Capture intact of any large war vessel would be a prize worth much to a Klingon ship commander. If boarding was not possible, however, the commander would not hesitate to destroy the offending vessel.

In areas of dispute, Imperial policy is less certain. The capture or destruction of an unfriendly (read: non-Klingon) vessel in such an area must be done with a minimum of fuss and attention. There must be no chance that word will reach the ship's home base to inform them of an unprovoked attack. The weight of the decision whether or not to risk such an attack rests solely with the commander present — and his career depends on not making the wrong choice.

In the Organian Treaty Zone, there is no margin for error, and commanders who serve here are under strict orders to risk no behavior that might attract the attention of the strictly pacifist Organians or endanger the treaty. Any clandestine operations here (such as the one depicted in *The Trouble with Tribbles*) are planned at the highest levels. A commander who goofs up such a mission will soon find himself before an Imperial Court, whose members will no doubt suggest he do the Empire a favor by quietly committing

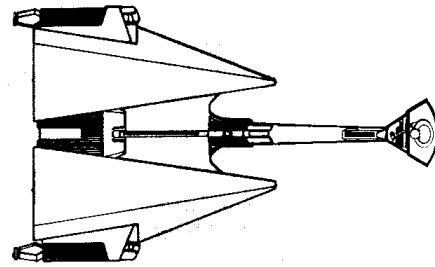
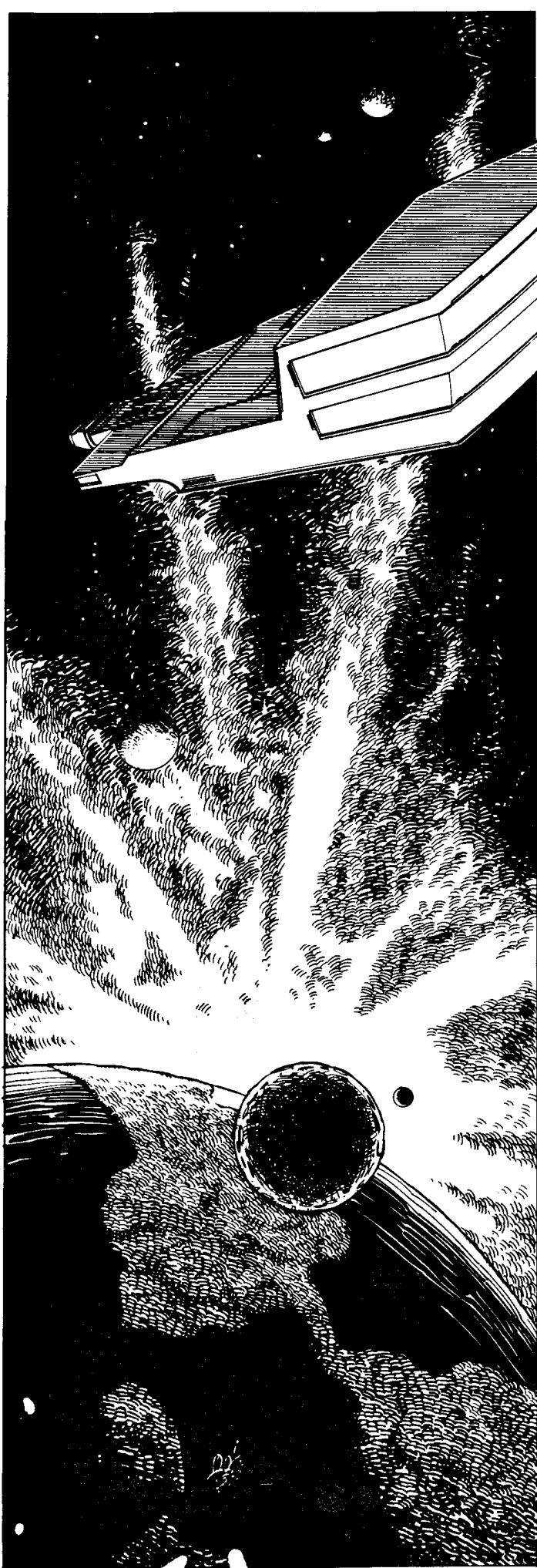

suicide. If he fails to do so, the Court will appoint someone to help him. Such commanders sometimes prefer to face Federation justice, or even turn pirate and never return to the Empire. The last alternative is dangerous, indeed — commanders who steal their ships are hunted relentlessly by Klingon security and often have a price on their heads in both the UFP and the Empire.

Klingon commanders must even be somewhat wary of other ships flying Klingon colors, if such ships are encountered unexpectedly, or if they are known to be under the direction of superior officers who are strong rivals of one's own superiors. In the Empire, one never is quite sure when one is being used as a pawn in the *komerex zha*, the perpetual game of power. More than one captain has been sacrificed — along with his ship — to gain a small political advantage for a superior officer or a powerful noble.

One cannot afford to make too many errors, or to express unapproved opinions to those one is not absolutely sure about. Every ship of any size is sure to have at least one clandestine agent of Klingon Imperial Security on board. The only way to be sure you can trust a fellow officer is to give him good reason to be concerned for your welfare — usually by having some sort of hold on him politically or professionally.

Remember that power within the Empire makes many minor shifts, mostly without warning. The prudent, flexible commander will be the most successful — and live the longest.

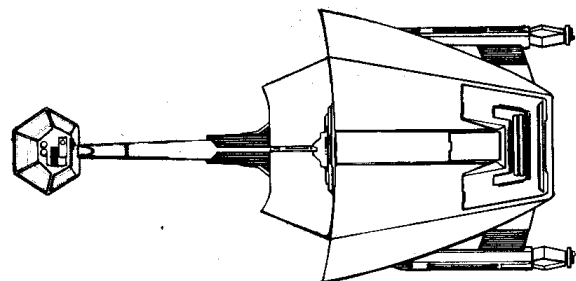

Gamemaster Hints and Suggestions

It might seem easy to gamemaster a free-wheeling Klingon Empire-based campaign, as opposed to the more structured UFP-centered game series. In truth, however, guiding a group of Klingon player characters presents unique problems and situations that sometimes make it *more difficult, not less, to have a Klingon campaign.*

Once again, gamemaster and players must first decide on a setting for the campaign — usually a ship of the Klingon Imperial Fleet. The D-7 Battlecruiser — backbone of the Klingon fleet and the most frequently encountered near the UFP — is a popular choice, and has many advantages. Most times, D-7 battlecruisers are deployed in squadrons of three, but near the Federation it is not uncommon to find them singly. (Such ships are officially assigned to a 3-ship squadron, but in truth spend most of their time on lone patrol...)

For groups of experienced players, a ship such as a D-11 or D-18 destroyer (both from the Klingon Ship Recognition Manual — Volume 1, available from FASA) provides a setting for a challenging campaign. Such ships are moved around a lot to trouble spots, making such a campaign likely to be somewhat combat-oriented.

For smaller groups, a campaign may be based on a K-23 or K-26 escort ship (also from the *Klingon Ship Recognition Manual — Volume 1...*). These ships, as their name suggests, escort convoys and merchant vessels. This can be exciting work, especially in areas of space disputed by the Romulans.

On most Klingon vessels, the relationship between officers and crew is radically different than on Federation Star Fleet vessels. Klingons tend to move around a lot, especially as junior officers. This is attributable both to the ambition of junior officers and to the paranoia of the High Command (who prefers not to let a popular or crafty officer get too much of a toehold in the heirarchy...). Thus, it is unlikely that player characters will have had time to develop much trust or loyalty among their own crew as the campaign begins.

This lack of trust is important to the tone of the campaign. All Klingon officers serve under the shadow of doubt. Junior officers all await their chances to supplant their superiors, sometimes actively plotting their downfall. As if danger from downranks wasn't bad enough, a player character must also watch out for trouble from *upranks*, where a superior officer may decide that you are too efficient, popular, or crafty and arrange an "accident" that removes you from contention for *his* position. Finally, the eyes and ears of Imperial Security are everywhere. You can never be sure that a quiet, unassuming non-player crewman is not secretly monitoring your conversations and making reports to Imperial Security.

Of course, monitoring internal security is the job of the Security Officer aboard ship — a very important and powerful job in the Empire. Security officers tend to be loners without friends, at once distained and feared by the military types. Most internal spying will be controlled and ordered by this officer, who may or may not be a player character. If the players are inexperienced, or having trouble thinking like Klingons, it may be best to have the Security Officer as a non-player character. This character can be set up in an adversary role to the player-character Captain, questioning everything he does and making sure he toes the line politically.

In campaigns with experienced characters, the Security Officer may be a player character. The adversary relationship may still exist, of course. Also, there may be other clandestine operatives of the Imperial Security branch not known to the Security Officer. The assignment of these operatives is to watch the Security Officer himself. If he and the Captain get too chummy, and begin to plan operations not in the interest of the Empire, the clandestine agent may step in, or call in other help.

1 An interesting arrangement for groups of experienced players is to choose a junior officer from among the player characters to actually BE a clandestine agent of Klingon Imperial Security. Before the campaign starts, the player is secretly informed of his status and provided with TWO character sheets. The sheet he uses most of the time shows only his cover identity, while his HIDDEN sheet shows his actual rank and capabilities (usually higher).

This can get very interesting as the campaign progresses, if the covert agent's player is clever, subtle and really into his role. Complications arise when such a player requires a saving roll on a skill or statistic that is actually higher than his public role (and public character sheet) would indicate. All rolls are attempted on the publicly-known score levels. If the roll fails, (but would have succeeded using the character's true capabilities) the player chooses whether or not to reveal his greater abilities. In situations where the roll does not represent a life-or-death situation, the player may simply accept the "failure" to protect his cover. Where the roll is important, though, the player may simply say "I made that roll" and continue play. If the roll is questioned, the gamemaster simply confirms that the roll is O.K. without comment. This, of course, risks making the other players suspicious.

It is the gamemaster's job to keep Klingon players nervous about their status, one way or the other. Player characters should be encouraged to keep an eye on their superiors' jobs — watching for a chance to advance. Outright assassination of superiors is very rare, except when such assassination is sanctioned by higher level officers who will protect the assassin.

(Of course, it is possible for a high-ranking officer to encourage you to assassinate your immediate superior, only to double-cross you and claim you acted alone. Thus, he removes BOTH of you by turning you over to Security!)

A safer way to advance is to set your superior up with bad advice or incorrect intelligence. When he fails an important mission, your unfavorable report may lead him to be reassigned, busted in rank, or — in very extreme cases only — terminated, allowing you to move up. Be careful, however, as your own subordinates may have the same thing in mind.

To protect one's own position, it is common for ranking officers to gather damaging information on subordinates — information that will be revealed if the ranking officer is double-crossed or mysteriously is killed in the line of duty. Sometimes, it is safest to HOLD damaging reports to be used later if necessary.

The Klingon High Command unofficially *encourages* such behavior (though officially you can lose your command and your life if underhanded actions come to light when you are in disfavor). After all, it is to the High Command's advantage to keep officers too busy to consider moving in on *them!* Too much infighting makes crews inefficient, however, so High Command will act to remove an officer who is too ambitious or too much of a troublemaker.

If it sounds like it's hard for a gamemaster to keep a good balance of power and paranoia — you are correct! Running a Klingon-based campaign requires excellent role-playing and even better gamemastering. But the results can be very rewarding when it works.

Klingon approaches to various outer-space assignments are a bit different than the practices of their Star Fleet counterparts. The Klingons tend to be more free-wheeling and less concerned with the rights of individuals and cultures when such rights interfere with the demands of the Empire or with attainment of personal prestige. The good gamemaster will still keep the players from running roughshod over the galaxy, however, by making sure their assignments have built-in complications.

Of course, the simplest "complication" to implement is adventures set in the Organian Treaty Zone. If the players' ship is assigned in this area, normal Klingon diplomatic tactics (orbital bombardment, Marine occupation forces, torture of citizenry, etc.) will not be tolerated. Not only must a commander fear Organian action, but he must fear Imperial intervention! The Empire cannot risk a treaty violation that can be traced to them, and will punish severely any commander who takes too many chances.

In the Treaty Zone, characters must approach assignments such as first contact, negotiation of alliances and treaties, planetary exploration and exploitation, etc. from a more relaxed military posture. This is not to say that they must completely emulate the Federation's policies — rather they must use every legal advantage they can grab — and then create a few "advantages" *without getting caught!* This requires shrewd planning by Klingon commanders (and a watchful eye by gamemasters).

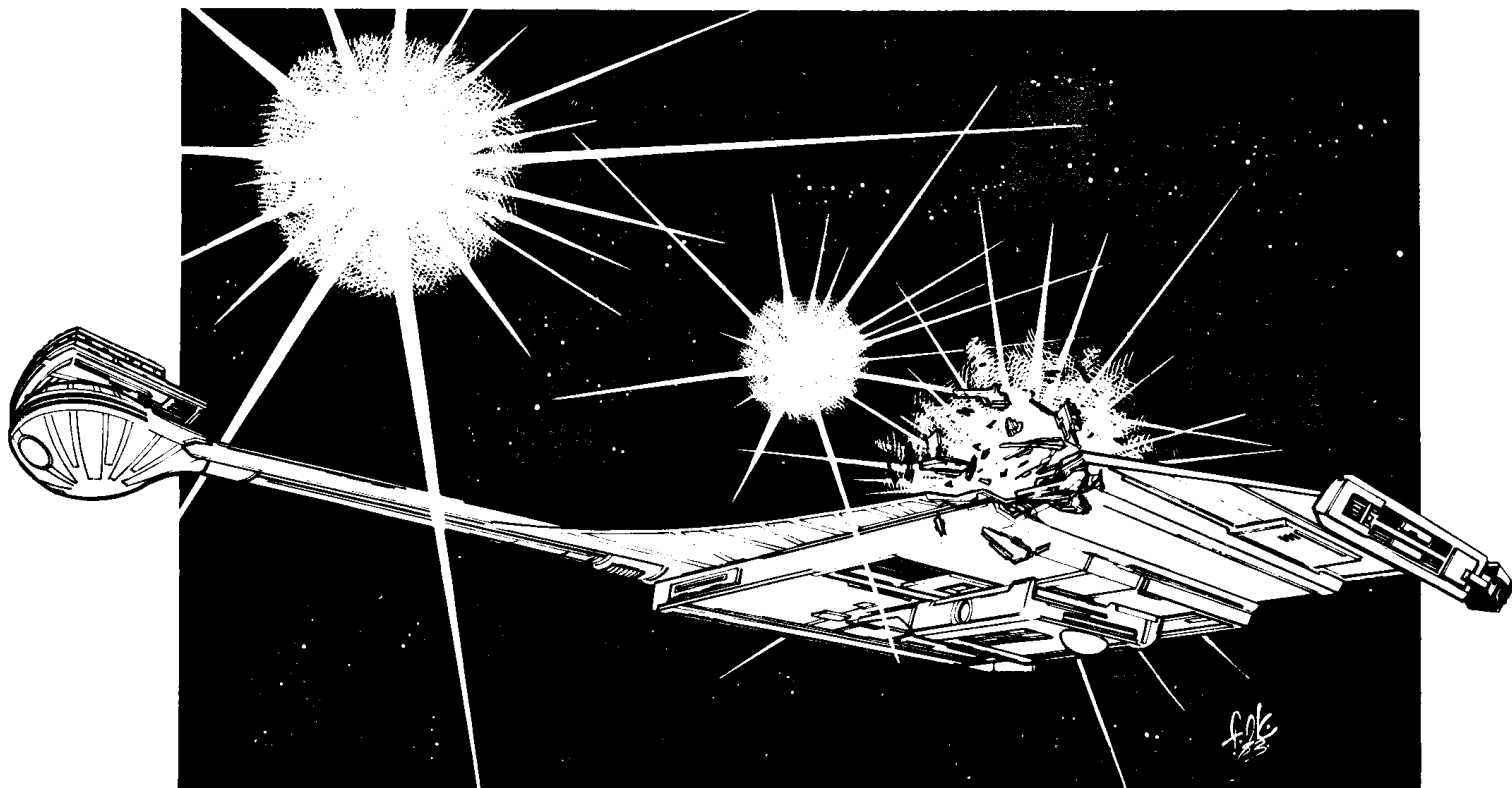

As a gamemaster, don't fall into the practice of endlessly frustrating all the sneaky tricks the Klingon players think up. After all, in this campaign the Klingons are the "good guys" and should not lose every time. Failing assignments on a regular basis is a good way to bore players. A clever plan deserves to succeed. On the other hand, it is best not to let players gain too much of an advantage, especially in important diplomatic conflicts with the Federation. Maintain the balance of power in important concerns. (Unless, of course, you plan to allow the campaign to develop into a variant STAR TREK universe where the Klingons get the upper hand! If you and your players have a secret desire to blow up the *Enterprise* and move in on Federation space — have fun!)

The best place for Klingon adventures, however, may be deep within the Empire itself. There, the usual foes are other factions of Klingons, competing for Imperial concessions and power. Starship captains and crews are often used as pawns in such struggles, but a determined "pawn" can cleverly play one faction off another and be promoted to a "queen" of battle with a powerful faction of his own. The long-term goal of a ship commander may be to found his own line and gain enough Imperial attention and power to become an influential Klingon noble in his own right. Attainment of such a goal should come after much clever campaigning, which will no doubt include several setbacks and a large number of dangerous assignments. The best way to accumulate power in the Empire is to establish a reputation that makes others afraid to cross you and eager to do you favors (to receive favors in return later). That means you must accept dangerous work and gather glory for the Empire (which will reflect on you as well.)

The nature of Klingon campaigns will lead to the demise of more player characters than is normal in UFP-based games. Thus, it may be best for players to have more than one character each. One character, usually the one with higher rank and position, is a primary character who is "played" most often. The other should be a junior officer, who may or may not be attached to the same department. Both may be active in the same adventure, and a good player should take advantage of opportunities that arise for either to increase in status or glory.

In some cases, two characters played by the same player may be friends or even linebrothers. Such characters will watch out for each other to some extent, and may act out of revenge if the other is double-crossed. Some characters may be neutral to each other. Every now and then, a player gets a kick out of playing two characters whose ambitions and positions put them at odds with one another at times. The ultimate in role-playing comes when one of a player's characters backstabs the other at critical moment to further the character's own ambitions. Gamemasters should set up such situations only with experienced role-players who can be counted on to stay in character even when the situation goes against him. Gamemasters should NEVER allow a single player to hold two very powerful characters — especially if they

are natural adversaries like a Captain and Security Officer. That would be too much temptation for even the best role-players!

Remember when helping players create characters that Klingons can be as three-dimensional as Star Fleet characters. Klingons have hopes, fears, likes, dislikes, families, friends, ambitions and personality quirks. Encourage individuality within the Klingon mold. Too much eccentricity, however, would only be tolerated in the most efficient and valuable officers. Still, there is plenty of room for variation.

Once you have a campaign background and a set of well-developed characters, you can plan adventure situations. Some of these will be very similar to those encountered by Federation vessels, but the Klingon approach to the problems will be different. An unknown derelict vessel presents an intriguing mystery to both UFP and Klingon Empire crews, but the UFP group would be thinking about aiding survivors and investigating the causes of the accident while the Klingons would be interested in salvaging valuable bits of alien technology or looting other items of interest — and in protecting Imperial security by capturing and interrogating survivors.

The typical medical emergency call would come to Klingons as well as UFP crews, but would be handled differently. Is it important to rescue all members of an agricultural colony stricken by an unknown virus? Perhaps it would be better to save important command personnel and let the servitor race who does the actual work die off — especially if the planet is controlled by a rival line whose fortunes would be crippled if that happened. Of course, one must take precautions against retribution and make the "rescue effort" at least look sincere to the Imperial Council...

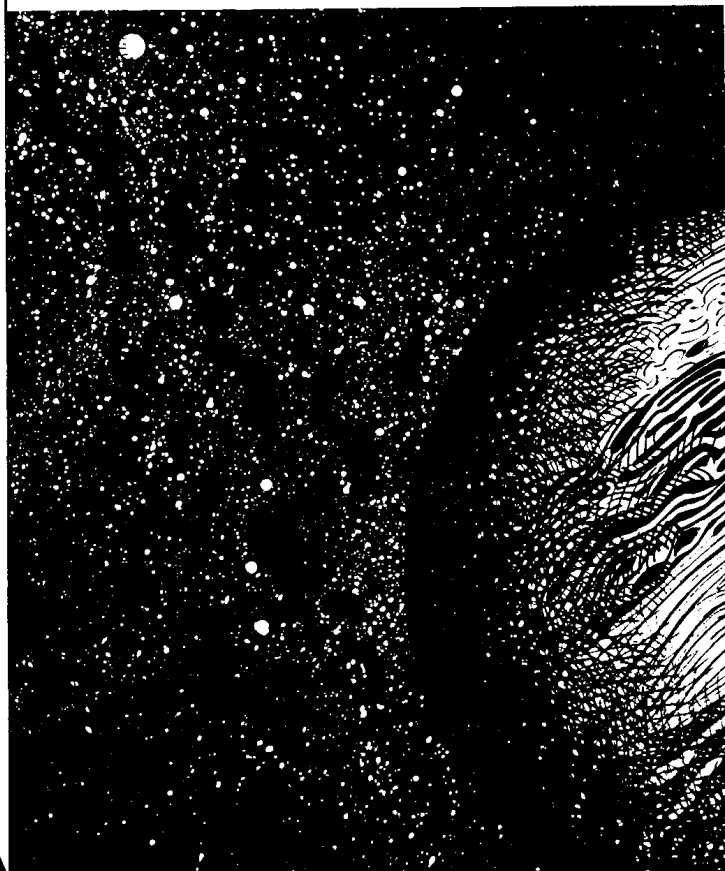

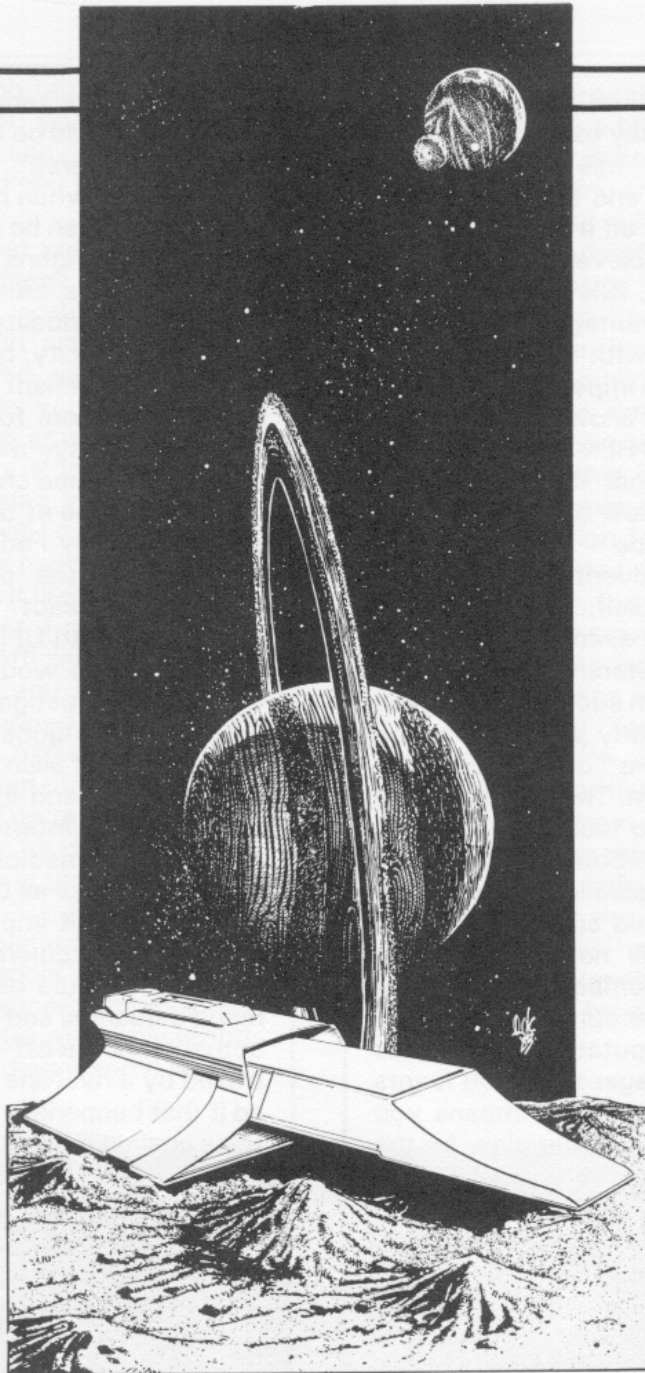

Captains called upon to undertake mysterious missions had better be very careful in doing so. Is the mission all it seems to be? Is the ship and crew being used as part of a power play by an ambitious noble? If so, how can you get your share if the mission is successful, or protect yourself if it fails. (And what would it be worth to rival factions to assure the mission's failure...) Of course, the whole thing may be a trap set by Imperial Security to check your loyalty.

The possibilities for twists on familiar STAR TREK plotlines are endless. How would the Klingons have handled Korob and Sylvia in *Catspaw* or Trelane, the Squire of Gothos? Could they have been resourceful enough to stop *The Doomsday Machine*? Even some of the published STAR TREK adventures from FASA could be reworked for Klingon player groups. (Notably *The Vanished*, raising the possibility that the alien I'lglii might encounter the Empire's forces, too.) Use these ideas as springboards to your own brand of STAR TREK universe adventure.

A Short Note: Klingon Epithets

As players get "into" their Klingon characters, they will no doubt begin to express varying degrees of animosity for other cultures, particularly the Federation. We present here a short discussion of favorite Klingon epithets, for providing a little color to Klingon campaigns.

Of course, the favorite derisive terminology for representatives of the Federation is "earther". This term is applied by Klingons to any member of the human race, whether or not the individual was born on Earth. The name is more derisive than it sounds, as it implies that Earth dominates the Federation — such domination by anyone but the Empire being an intolerably insulting idea to a Klingon. The term is never applied to members of races not physically similar to humans.

Vulcans are both respected and despised by the Empire. They are respected for their technological accomplishments and their stoicism, but their pacifistic nature and vegetarianism is anathema to Klingons. Thus, a Klingon will often publicly denounce the Vulcans, but will rarely underestimate them. Vulcans are known as "leaf-eaters" and "calculating machines", but Klingons are quite aware that they can trust what a Vulcan tells them, since Vulcans do not lie directly (though they may conceal the truth). To a Klingon, lying is a way of life, and the compulsive truthfulness of the Vulcans somewhat unnerves the average Klingon — though a Klingon will take advantage of this trait when it suits his purposes.

Andorians, known as fierce warriors, are not respected by Klingons because of their acceptance of the Federation. Klingons see the Andorian moves toward peace as signs of fundamental weakness in an otherwise respectable warrior culture. Once *komerex* — a growing empire — the Andorians are now *khesterex* — a dead culture — in Klingon eyes. Thus, they are fit only for conquering or extermination. There is a hint of sadness in Klingon relationships with the Andorians — a touch of regret that the two will not meet in glorious battle after all.

The greatest insult a Klingon can pay another is to refer to him as a slave. The concept of "slave" is much different than the concept behind the *klingtonaase* word *kuve* — literally "servitor". To the Klingons, there is no shame in being a servitor to another race. Indeed, it is their philosophy that the great majority of races are predestined and intended to be the servitors of the Klingon race. This is a respectable position, bringing honor to the person who does it well. A "slave", on the other hand, is one who serves when he was intended to conquer. He serves from weakness and cowardice. The Andorians may fall into this category eventually, the Klingons believe, whereas the Vulcans were never intended as conquerors and may serve honorably. The decision is less clear for the human race, and this point is the subject

of a continuing debate by what passes for philosophers among the Klingons. In any case, to call a *Klingon* a "willing slave" is the deadliest of insults.

Finally, remember that traditional human insults may not mean the same thing when translated into *klingtonaase*. "Your mother wears army boots" would probably come out as "your maternal parent wore the footgear of a soldier" in *klingtonaase*, and be considered a compliment to the military standing of one's line. References to the legitimacy of one's birth are not likely to be understood at all, due to differing Klingon customs of marriage/mating.

Insults are an artform among Klingons. The best canonical example of which is the speech delivered by *zan* Korax in *The Trouble with Tribbles*. (*Zan*, by the way, is the *klingtonaase* equivalent of the military term "Mister" as applied to an officer of either sex.)





DESIGNER'S NOTES

There's little left to be said, actually. The usual notes on how design decisions were made (and the explanations of the project's origins) were mostly incorporated in the Introduction, or worked into the text where it would be most useful, informative and/or interesting.

One point remains to be touched upon, however. At first it may be a bit confusing to see this book — whose primary purpose is to provide background for campaigns featuring Klingon player characters — present most of its material from the Federation point-of-view. (The excerpts from the UFP-published book *An Informal Guide to the Klingon Empire* being the best example of this approach.) Truly, however, there is a method to our madness.

For one thing, most of what we (as the compilers of this expansion set) know about the Klingon Empire is based on the Federation viewpoint, as presented in STAR TREK. Had this game been titled "BATTLECRUISER VENGEANCE: The Role Playing Game" (a reference to a favorite Klingon video presentation), the result would have been much different. STAR TREK presented the Federation view of the Klingons, so concrete evidence from the series MUST be colored by this view.

John M. Ford's unique viewpoints (based on his upcoming novel *The Final Reflection*) DO allow us to present the Klingon side as it has never been presented before. Even so, to approach this book as if it were written by Klingons FOR Klingons would not ring true. A Klingon author would not bother to explain the concept of "the naked stars" or how linename prefixes work — it would be an integral part of his cultural heritage needing no explanation.

Unfortunately (at least, from the Klingon point-of-view) you — the reader — do not have the advantages of growing up in the Klingon cultural background. All the readers of this book will be Earthers. (If you are an excep-

tion to this statement, please write us immediately! Such a deal we have for you . . .) For this reason, the Klingon material must be presented against the more familiar background of the Federation to some extent.

For role-playing game purposes, you will want to try to think and act like a Klingon when playing a Klingon character. (Here's hoping you won't want to think and act that way OUTSIDE the game! It's not a viable lifestyle on 20th century Earth . . .) The background, we hope, will help you to do that. But before one can appreciate the Klingon philosophy (short of being exposed to it directly from birth), one must have it explained within the context of one's own culture.

Adventure material (starting with the adventures accompanying this set) can and will be presented with the Klingon viewpoint uppermost. Once again, we do not ADVOCATE the Klingon view of life and the universe, but the goals of our adventures will reflect those views as an exercise in role-playing. Trying to play such adventures with human-oriented goals and ideals will often cause players to meet with failure, as it should.

Thinking like a Klingon is not just a matter of "thinking mean", as even a few minutes perusal of this book will reveal. The Klingon culture has an internal logic and order as subtle and well-formed as our own. Klingons love, hate, fear, enjoy, and experience other emotions just like humans. The things that *inspire* such emotions, and the ways in which they *express* these emotions, however, are often much, much different. This is what makes playing a Klingon character such a fascinating challenge. With this book as a bridge between our culture and that of the Klingons, you can attempt to meet that challenge and broaden the horizons of your gaming experiences.

Guy W. McLimore, Jr.
Fantasimulations Associates

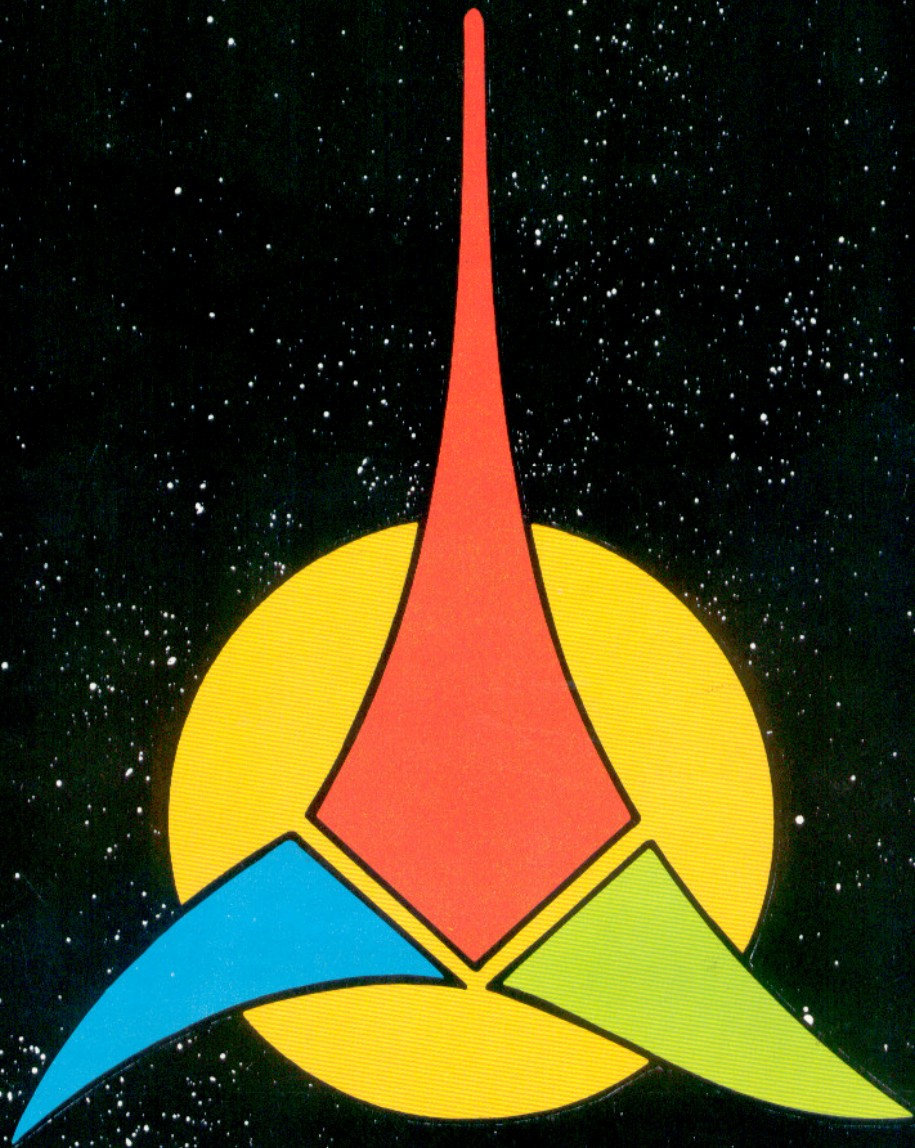

KLINGON